

To ensure good drive control service and its safe use, please read the following instructions carefully before using this product and its electrical and mechanical systems. In order to continuously improve and improve the products and related materials

1. Mechanical and electrical installation instructions

Before installation, please make sure that the drive is in the power off state, it is forbidden to insert the power plug
Remove the pre-sealed cover on the C-type SLOT3 card slot and insert the option vertically after inserting the option. After opening the R-type cover, insert the option from SLOT5 and lock it with the screw.

Use a flat-blade screwdriver or standard DB9 and DB15 heads to complete the wiring according to the wiring diagram after checking the model.

The wiring diameter is AWG14~24 (2.1~0.2mm²), and the terminal torque is up to 5kgf-cm.

To prevent interference, use a qualified shielded cable, and do not route alongside the AC220V and above circuits, and keep the distance between the motor and power cables at 15CM or more. When interlacing, please observe the principle of vertical wiring.

When connecting an inductive load (relay, electromagnetic contactor, motor, etc.), install an arc eliminator (RC absorber) on the coil side.

Try to control the length of the wiring (because this length is inversely proportional to the signal frequency).

Please use this product in a non-corrosive gas, liquid and dust-free indoor environment.

For safety reasons, please install a fuse in the circuit (the specification cannot be greater than the contact limit)

**Do not plug or unplug this card with power, otherwise the machine may be damaged.
Before the signal is connected, it must be confirmed that the motor is well grounded,
otherwise the motor is inductive and has the risk of electric shock and equipment.**

This product is a static-sensitive component. Although it has been treated with anti-static damage before leaving the factory, it is recommended that you minimize unnecessary hand-free contact during the installation and use process to avoid damage.

DB Plug eg.



2. Specifications

Universal DB series gold-plated solderless terminal block connector, as above

1	High-speed differential encoder module	+TTL33	9+15Pin+C type, Non-isolated, high-speed differential encoder
2	Resolver encoder module	+RT35	9+15Pin+C type, Suitable for rotary transformers with excitation voltage of 7V and transformation ratio of 0.5
3	SinCos encoder module	+SN34	9+15Pin+C type, for resolver type encoder, frequency doubling inside
4	HTL pulse encoder module	+HTL39	9+15Pin+C type, HTL pulse encoder by DC12V, frequency dividing inside
5	TTL pulse encoder module	+TTL39	9+15Pin+C type, TTL pulse encoder by DC5V, frequency dividing inside
6	HTL pulse encoder module	+HTL52	9Pin Screw+R type, HTL pulse encoder by DC12V
7	Resolver encoder module	+RT55	9+15Pin+R type, for resolver type encoder
8	HTL pulse encoder module	+HTL59	9+15Pin+R type, HTL pulse encoder by DC12V, frequency dividing inside
9	TTL pulse encoder module	+TTL59	9+15Pin+R type, TTL pulse encoder by DC5V, frequency dividing inside
10	DB15VGA female plug with 15pin	+DB15F	Plug in X31 on C and R type drive with DB15 Pin
11	DB9VGA male plug with 9pin	+DB9M	Plug in X32 on C and R type drive with DB9 Pin
12	C type speed feedback card terminal type wiring adapter card	+DB9 15	Adapted to the speed feedback card of the C-type 9+15Pin interface

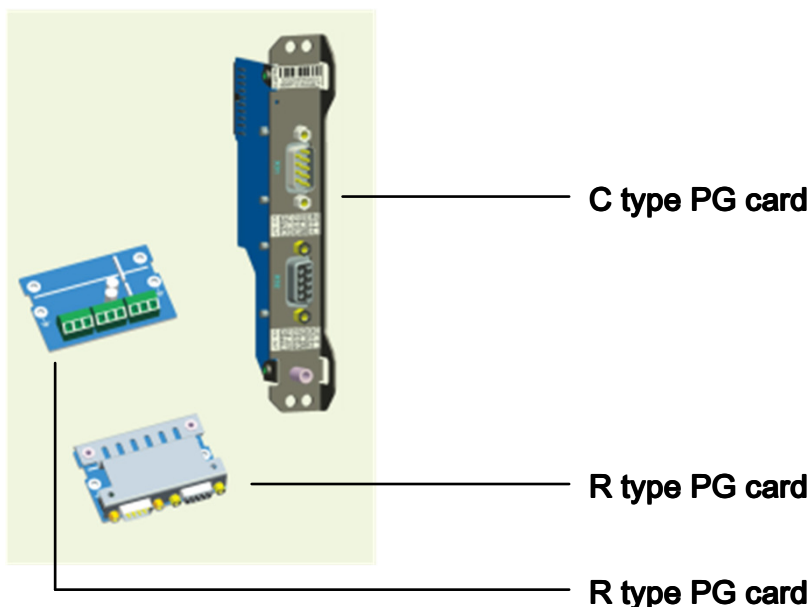

Specification				
Excitation voltage(Vrms)	Excitation frequency	Resolution	Frequency division range	Transformation Ratio
7V	10KHZ	12 bit	1:1	0.5

DB9 Port		
Pin number	Pin definition	Description
1	NC	None
2	EXCLO	Excitation -
3	SINLO	Feedback SIN -
4	COS	Feedback COS +
5	COM	Ground (0V)
6	EXC	Excitation +
7	SIN	Feedback SIN +
8	COSLO	Feedback COS -
9	NC	None

DB15 Port		
Pin number	Pin definition	Description
1	AO+	Differential output
2	AO-	
3	BO+	
4	BO-	
5	ZO+	Open Collector output
10	ZO-	
7	AO	
8	BO	Differential/PNP/NPN input
9	ZO	
11	PA+	Differential/PNP/NPN input
12	PA-	
13	PB+	Differential/PNP/NPN input
14	PB-	
6	COM	Ground (0V)
15	COM	

Figure 1 +RT35 DB9/DB15 Port Definition

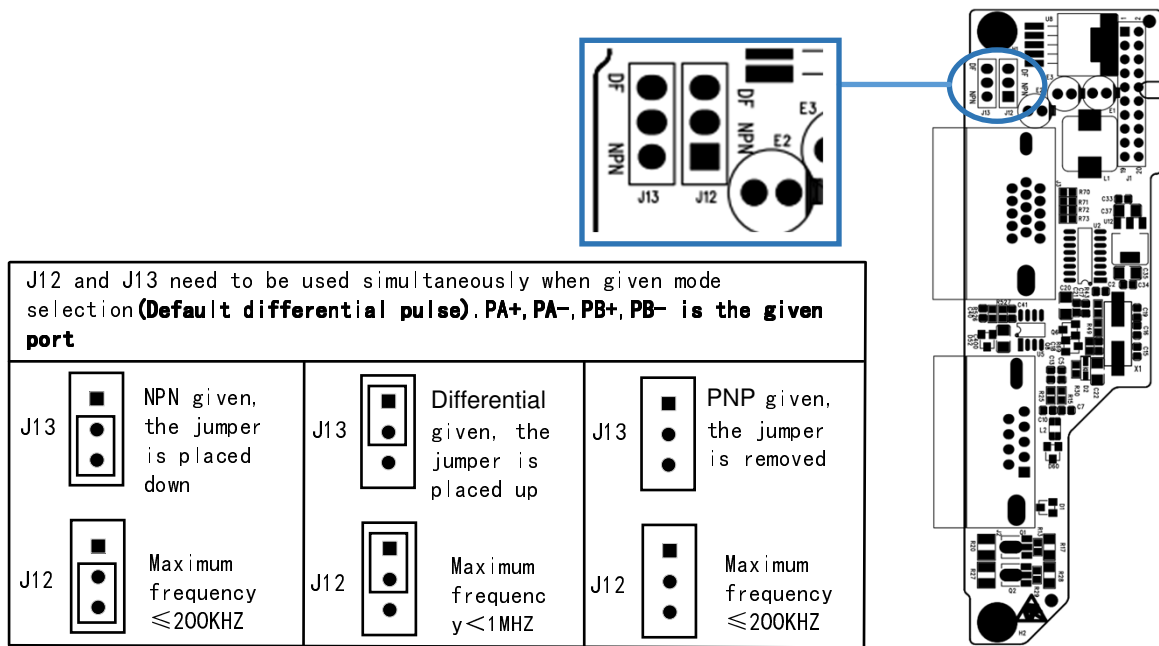

Figure 2 Control System Pulse Given Selection

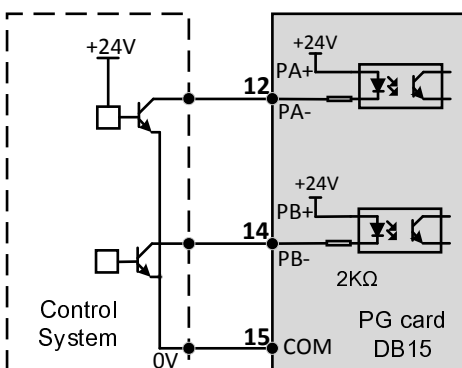

Figure 3 NPN pulse given wiring diagram

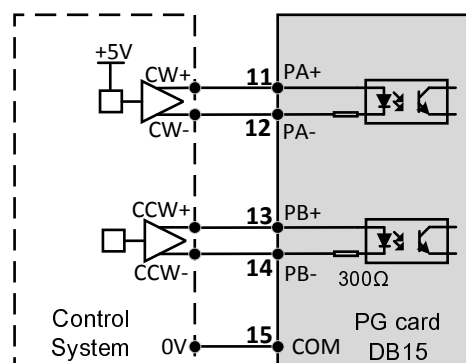

Figure 4 Differential pulse is given wiring diagram

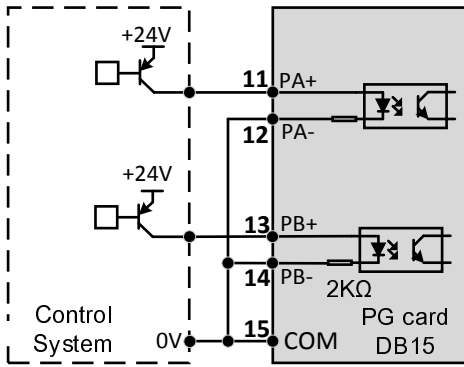

Figure 5 PNP pulse given wiring diagram

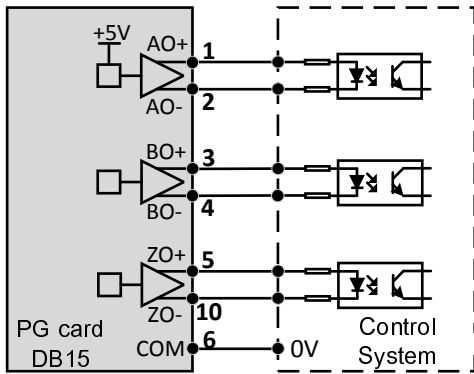

Figure 6 Differential pulse divider output wiring diagram

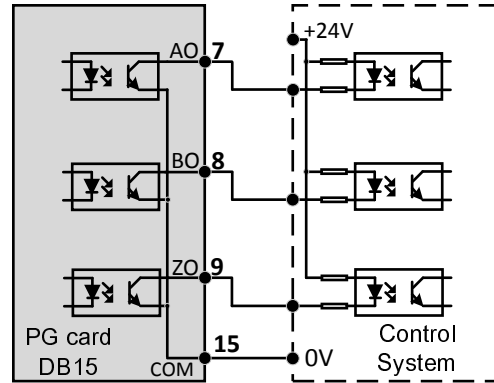

Figure 7 NPN pulse divider output wiring diagram