

AST6100 Intelligent Online Soft Starter

7.5KW-1000KW 380V-1140V

User manual



210611025

REV: **V216**
Jun.2021



Safety Clauses

Thanks for your using intelligent motor online soft starter, this product is used for three-phase squirrel cage induction motor soft starting and soft stopping control. Before using, please carefully read and understand the contents of this manual.

In the process of using the soft starter, please note the following Safety Clauses:



Please check this user manual carefully before using the product.



Only the technical person is allowed to install the product.



To be sure that the motor is correctly matched with the soft starter.



It is forbid to connect capacitors to the output terminals (U V W).



Please seal the terminal switch insulation glue after finishing connect them.



The soft starter and its enclosures must be fixedly earthed.



During the maintenance and repair, the input must be off-power.

This user manual content may be changed due to technical reasons or modified. We reserve the updating right.

Table of Contents

1. Online Running Soft Starter	1
1.1 Online running soft starter profile	1
1.2 The main feature of online running soft starter	1
1.3 The main function	1
1.4 Technical specification	2
2. Nameplate Explanation and Inspection	3
3. Usage Condition and Installation	4
3.1 The usage condition	4
3.2 The installation requirement	4
3.3 The installation dimensions	5
3.4 Installation diagram	6
4. Connection and External Terminal	7
4.1 The external terminal	7
4.3 The communication interfaces	7
5. Control Panel and Operation	9
5.1 The operation of control panel	9
5.2 Parameters set and explanation	10
5.3 Parameters code function explanation	12
5.4 Helping message and explanation	13
6. Protection Functions and Directions	14
6.1 Protection classes and explanation	14
7. Test Run and Application	16
7.1 Power on to test running	16
7.2 The starting mode and application	18
7.2.1 Current-limit to start	18
7.2.2 Voltage ramp to start	18
7.2.3 Torque control + current limit or + voltage ramp to start	19
7.2.4 Current ramp to start	19
7.2.5 Voltage current-limiting double closed-loop start	20
7.3 The stopping mode and application	20
7.3.1 Soft-stopping Mode	20
7.3.2 Free-stopping Mode	20
7.4 Special application	20
7.5 Application examples	21
8. Online Running Soft Starter Cabinet	22
8.1 Product Function	22
8.2 The structure and installation method	23
8.3 The operation of control panel	24
8.4 Operation procedures and cautions	25
Soft starter MODBUS communication protocol	26
Quality Warranty	32

1. Online Running Soft Starter

1.1 Online running soft starter profile

Online running soft starter, the use of intelligent digital control; With the single chip processor as the intelligence center, thyristor module for actuators for full automatic control motor. It applies various squirrel-cage asynchronous motor control of load, the motor can smooth starting under any working conditions, protect the drag system, reduce the starting current impact on power grid, ensure reliable motor starting. Smoothly soft stopping function can effectively solve the inertial system surge problem, eliminate the drag system of inertial impact, that is traditional equipment cannot be achieved. Intelligent digital online running soft start equipment system with the complete protection function, extend the service life of the system, reduce the cost of system cost, improve the reliability of system and compatible with all the functions of starting equipment; It is a new ideal alternative for traditional star triangle starter and self-coupling decompression starter.

1.2 The main feature of online running soft starter

Reliable quality	<ul style="list-style-type: none"> • The computer simulation design. • SMT production process. • Good EMC performance. • The machine before delivery on the high temperature aging, vibration test.
Perfect and reliable system protection function	<ul style="list-style-type: none"> • Protection of no voltage, less voltage and over voltage. • Protection of overheating and starting time too long. • Protection of Input phase lost, output phase lost and 3phase unbalance. • Protection of starting over current, running overload, and load short circuit protection.
Maintenance function	<ul style="list-style-type: none"> • Fault self-diagnosis(short circuit, over voltage, less voltage, one phase grounded, motor overload, one phase lost, motor blocked, and intelligent software can inspect drag system working state). • Combination of modular design, according to the fault display content, quick troubleshooting.
Independent intellectual property products	<ul style="list-style-type: none"> • Independently software copyright. • Motor starting and protection proprietary technology. • Unique way to detect debug equipment and process.
Quick and thoughtful after-sales service	<ul style="list-style-type: none"> • Reliable performances lay the foundation of qualified service and quality. • Provide perfect system solution. • The timely and thoughtful Consulting Services. • Constantly improve the product performance according to user's opinion.

1.3 The main function

- Effectively reduce the starting current of the motor; Can reduce the distribution capacity, avoid grid expansion investment.
- Reduce the starting stress of motor and load equipment; Prolong the service life of the motor and related equipments.

- Soft stopping function can effectively solve the parking surge problem of inertial systems; That is a traditional starting equipment cannot be achieved.
- With six unique starting mode; To adapt to the complex motor and load, achieve perfect priming effect.
- With complete and reliable protection function; effectively protect the safety of motor and related production equipment.
- Online running soft starter, the application of network technology used motor control technology to adapt to the rapid development of electric power automation technology in the higher requirements.

1.4 Technical specification

Item		Description
Input Power Supply	Input Voltage	Three-phase 380V/480V/660 AC
	Frequency	50/60Hz
Adaptive Motor		Squirrel-cage three-phase asynchronous motor
Starting Times		It is recommended not to exceed 20 times per hour.
Control Mode		(1) Operation panel control. (2) Operation panel + external control. (3) External control. (4) External control + COM control. (5) Operation panel + external + COM control. (6) Operation panel + COM control. (7) COM control. (8) No start or stop operation.
Start Mode		(1) Current-limiting to start. (2) Voltage ramp to start. (3) Torque control + current-limiting to start. (4) Torque control + voltage ramp to start. (5) Current ramp to start. (6) Voltage current-limiting double closed-loop start.
Stop Mode		(1) Soft stop. (2) Free stop.
Protective Function		(1) Open loop protection for external instantaneous stop terminals. (2) Over-heat protection for soft starter. (3) Protection for too long starting time. (4) Input open phase protection. (5) Output open phase protection. (6) Unbalanced three-phase protection. (7) starting over current protection. (8) Running overload protection. (9) Under voltage protection for power voltage. (10) Overvoltage protection for power voltage. (11) Protection for fault parameter setting. (12) Load short circuit protection. (13) Auto restart or incorrect wiring protection. (14) Incorrect wiring protection of external control stop terminals.
Ambient	Place to be used	Indoor location with good ventilation free from corrosive gas and conductive dust.
	Altitude	Below 1000M. It have to rise the rate power when the altitude is more than 1000M.
	Temperature	-20 +45 °C
	Humidity	90%RH without dew condensation.
	Vibration	<0.5G
Structure	Protection Class	IP20
	Cooling Pattern	Fans cooling.

2. Nameplate Explanation and Inspection

Please check up the products before using, if in some problems; please do not hesitate to contact us with any request for additional information. Check-up the type of product whether it is the right one you order.

Nameplate and Model explanation:

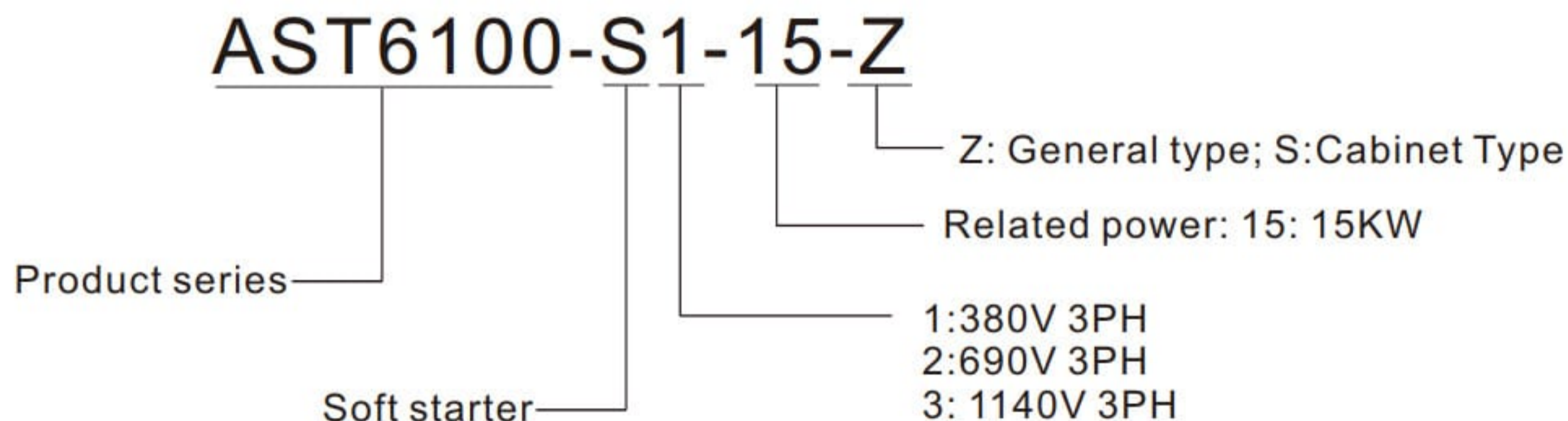
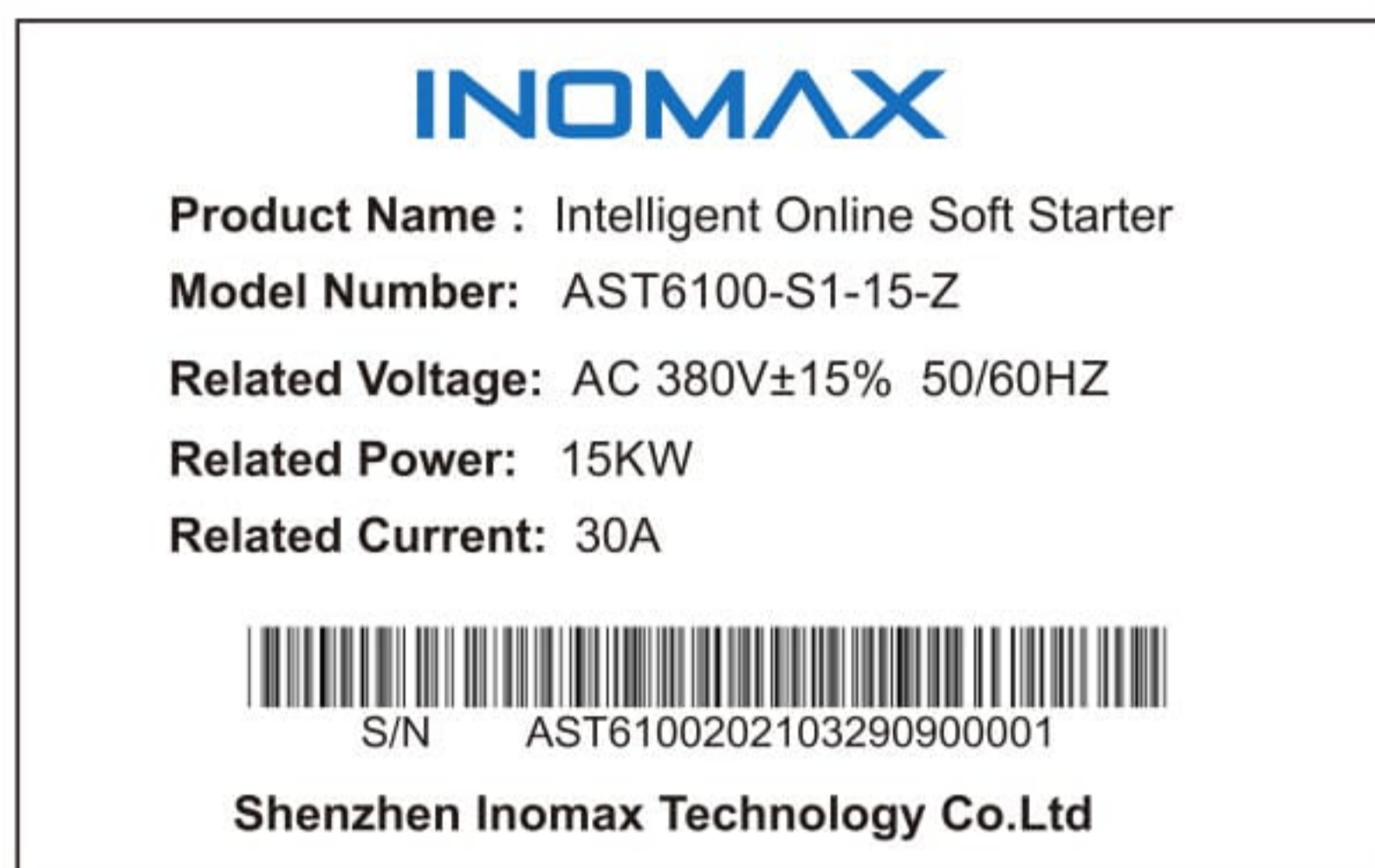

Diagram 2.1

- Check any damage to the product because of the transport, such as the spare parts are apart from the main body or the shell be damage etc.
- Check others, including the user's manual.

3. Usage Condition and Installation

It is strict rule for the users to use or install the online running soft starter according to the requirement; otherwise, it will be in bad result.

3.1 The usage condition

- **Power Supply:** City grid power, self-provided power, diesel oil dynamotor, 3-phase alternating current 380V/480V/660V \pm 15%, 50Hz or 60Hz. The power capacity of the online running soft start must meet the motor starting requirement.
- **Matched Motor:** Motor should be three phase squirrel asynchronous motor, and its power capacity must be matched with online running soft starters.
- **Starting Frequency:** The starting time is according to the loading equipments.
- **Cooling Mode:** Naturally wind cooling.
- **Protective Grade: IP20**
- **Environment Conditions:** when altitude is less than 1000m, the temperature of the environment should be between -20°C ~ 45 °C, relative humidity should be less than 90% RH, no vapor, no flammable, volatile, corrosive gas. No electric dirt, indoor installation, ventilated, vibration is less 0.5G.

3.2 The installation requirement

- The direction and distance of installation: In order to make sure that the online running soft starter be in good ventilation and heat dissipation, please install the product in vertical direction, and be sure the space around the product is enough. (See the following diagram 3.1)
- If the online running soft starter is installed in a box, please note that the ventilation is very good, as well as the above notes. (See the following diagram 3.1)

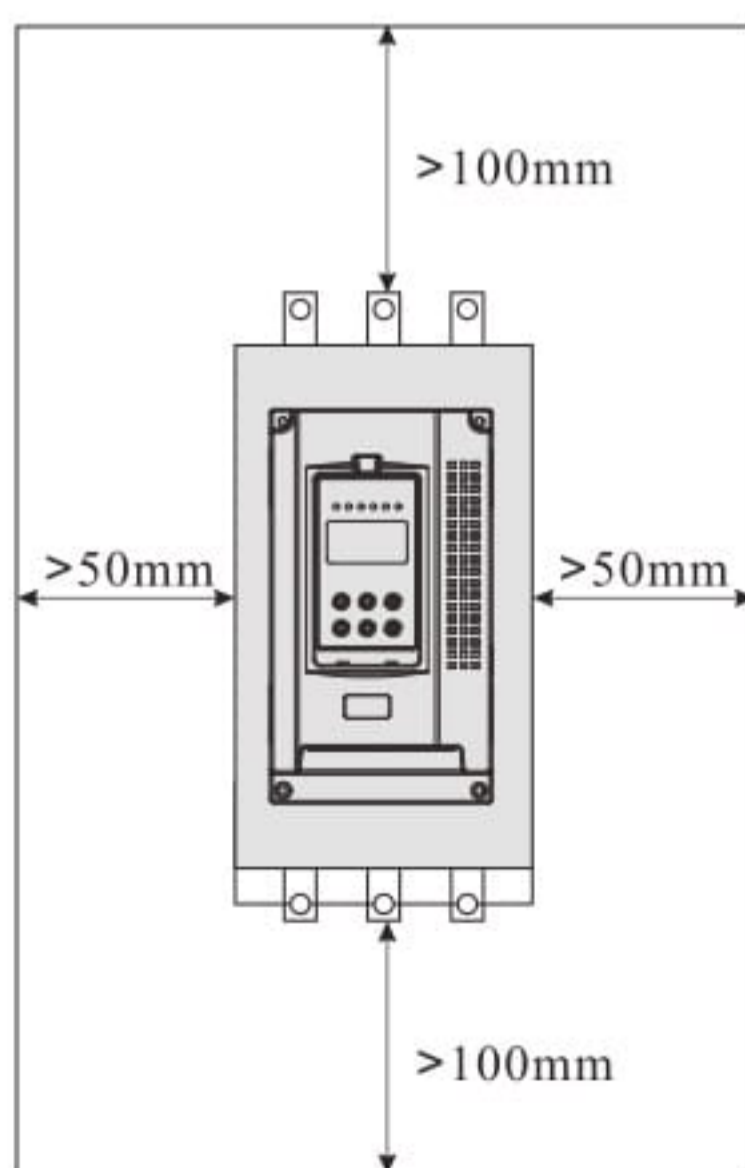

Diagram 3.1

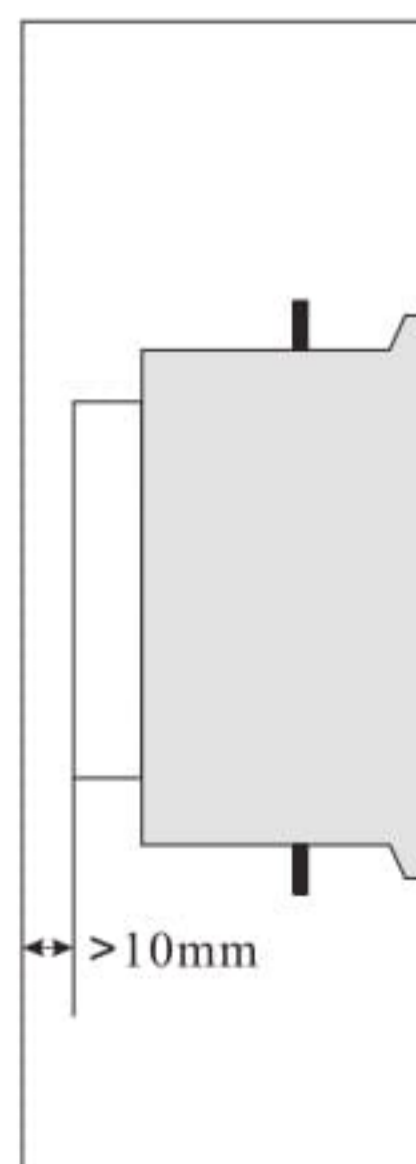

Diagram 3.2

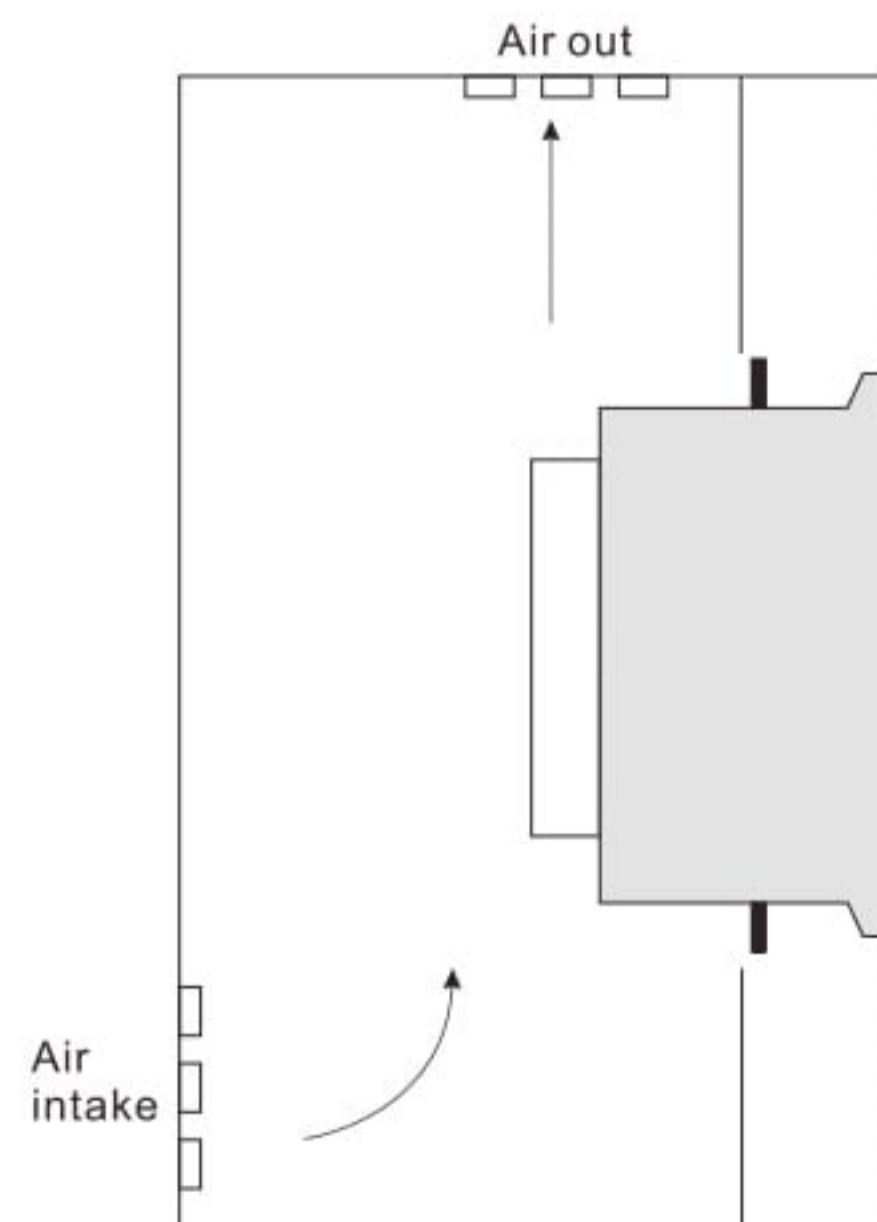
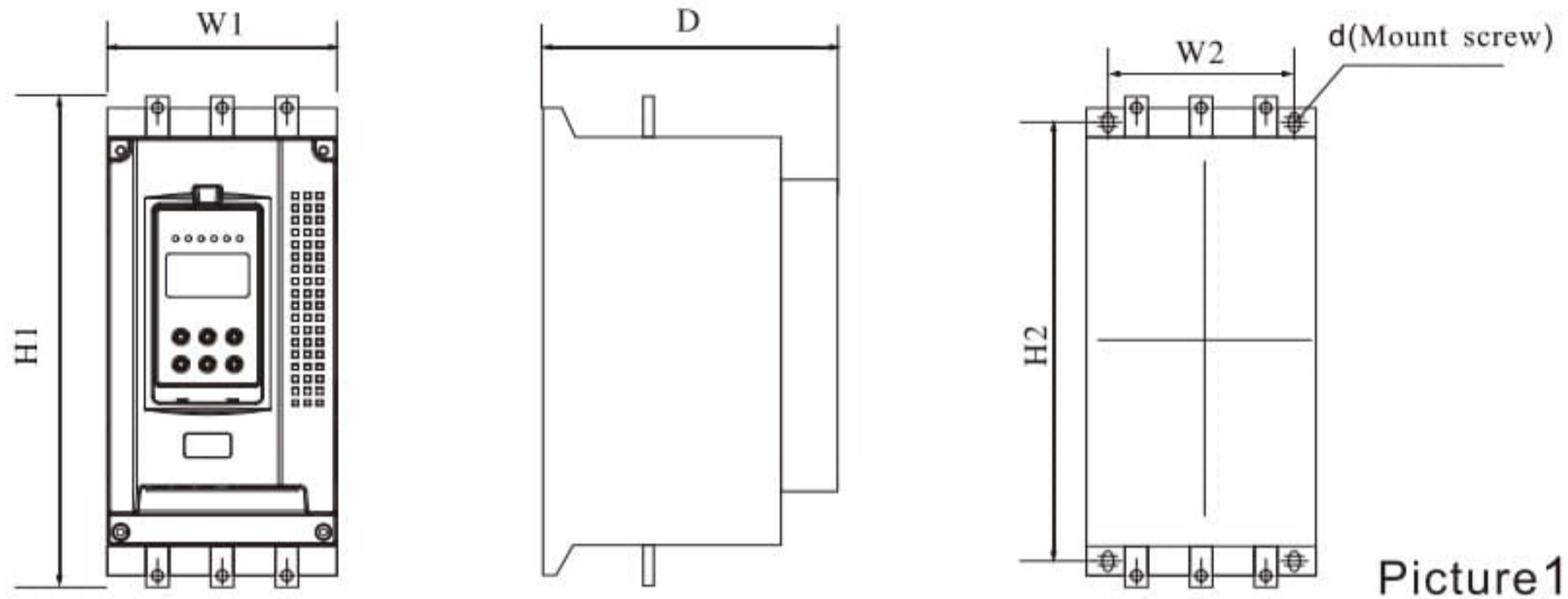
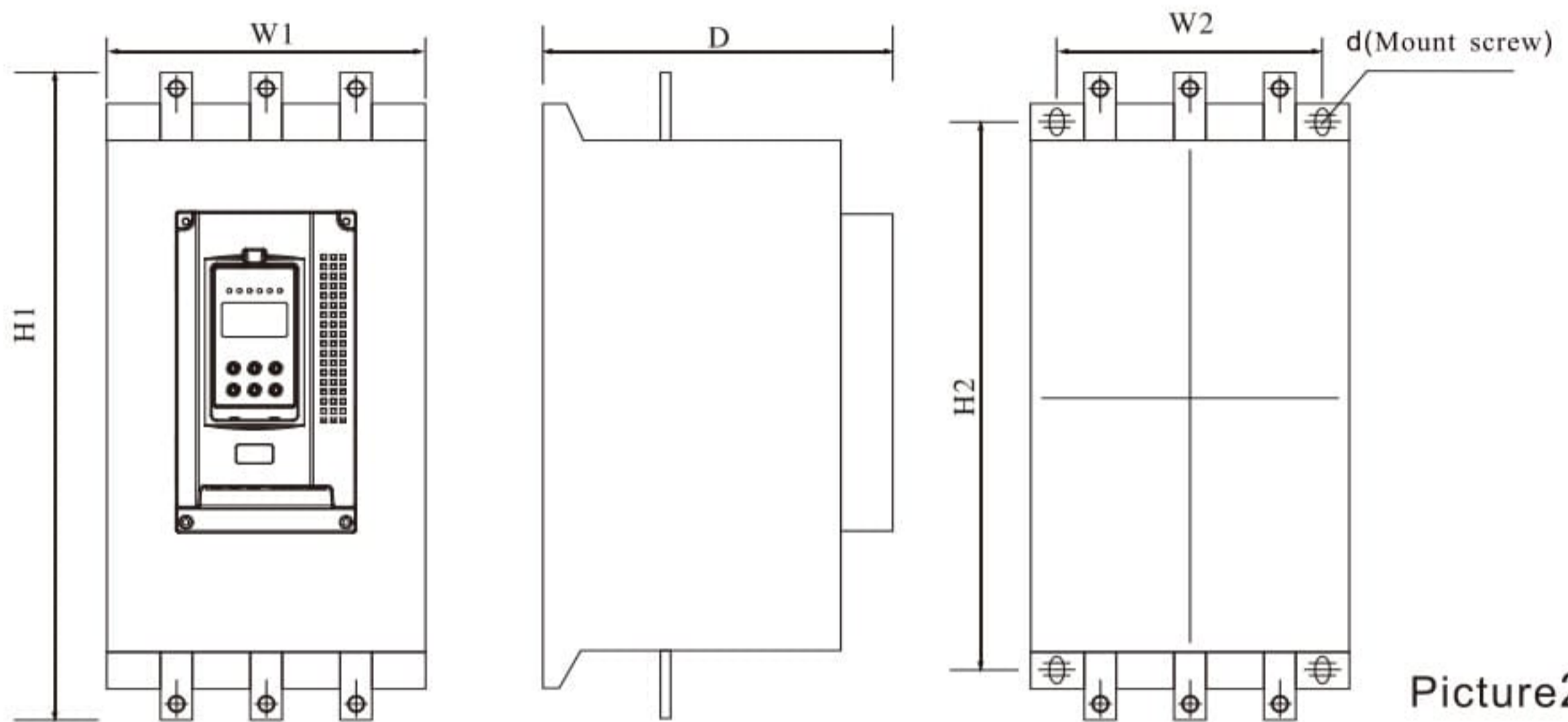

Diagram 3.3

3.3 The installation dimensions



Picture1



Picture2

Power	External Dimensions			Installation Dimensions			Outline drawing
	W1	H1	D	W2	H2	d	
7.5kW-55kW	150	330	202	116	285	M6	Picture1
75kW	172	355	220	140	300	M6	Picture1
90kW-110kW	210	394	253	150	343	M8	Picture2
132kW-185kW	330	496	255	260	440	M8	Picture2
200kW-320kW	490	608	295	335	535	M8	Picture2
400KW-630KW	680	840	408	350	780	M10	Picture2



: The rated power of motor in the above form is the maximum rated value. Generally, the values of matched motor power capacity should not be more than this value.

3.4 Installation diagram

The S6100 series online running soft starter has three types of connection as following:

- **Main circuit connection:** It contains the wiring of 3-phase source input, the output to motor.
- **External terminal connection:** That is the wire comes from twelve external terminals which including control signal and analogue output signal.
- **Communication connection:** One standard RJ-45 network cable socket and one DB9 socket can be used to connect computer or network.

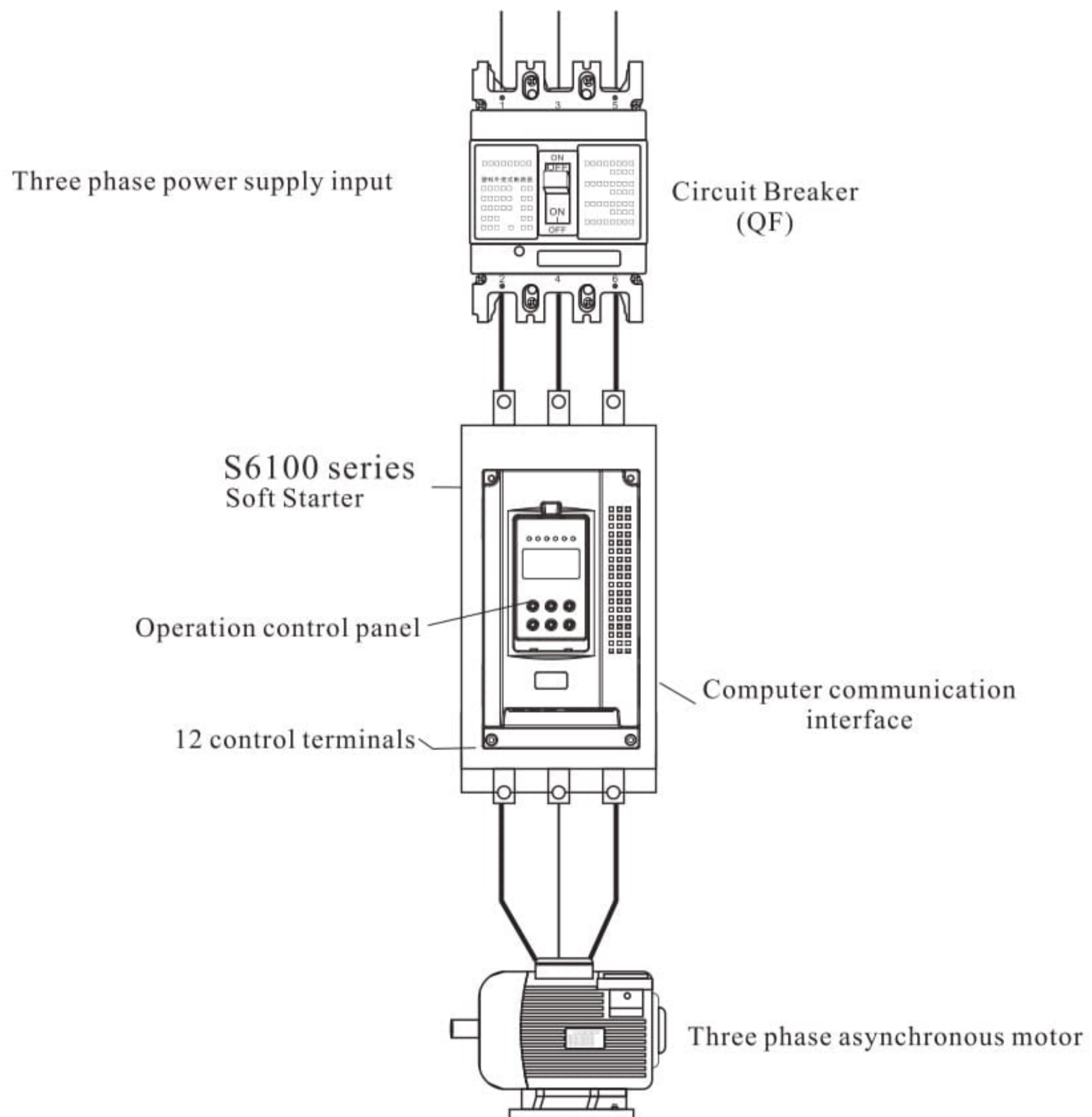

Diagram 3.4

4. Connection and External Terminal

4.1 The external terminal

Please see the diagram diagram 4.2:

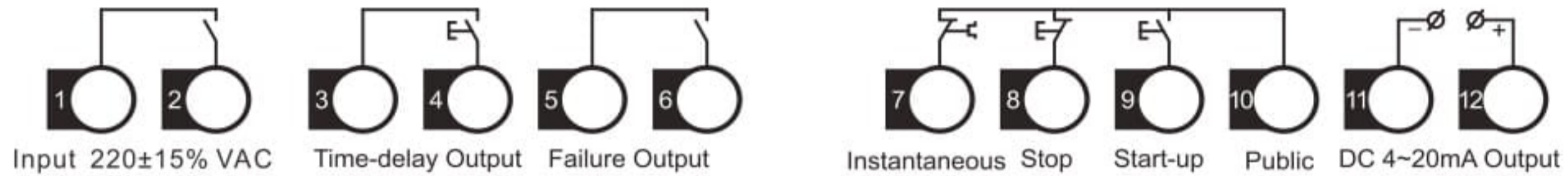
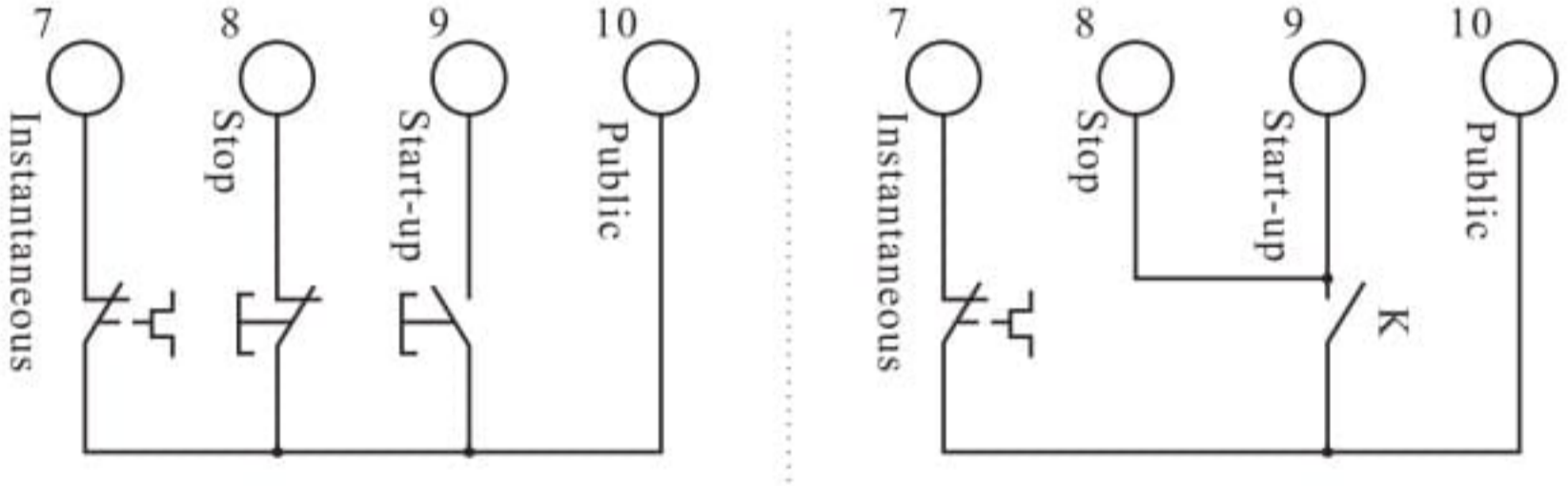

Diagram 4.2

No.	Name	Description
①②	Power supply input	The screen display is 220±15% VAC
③④	Programmable relay output	The delay time is set by FE code. The output command type is set by FE code. They are normal open no-power terminals, being close when output valid. Please see the detailed information in item 5.3. This terminal contact capacity is AC250V/5A
⑤⑥	Fault output	They will be closed when there are any fault matters happened to the online running soft starter or electricity lost, while at normal case they are open. This terminal contact Capacity is AC250V/0.5A.
⑦	Instantaneous stop input	This terminal must be connected with terminal ⑩ when the starter works normally. But if these two terminals are open, the online running soft starter will stop, and at this time the starter is at the state of fault protection. This terminal ⑦ can be controlled by the normally closed output terminals of external protection device, and it is useless when the FA code is set to 0(Primary protection).
⑧⑨⑩	External start up or Stop input	There are two ways of connections for your selection; those are 3-wire connection and 2-wire connection, as below:  <p>3-Wire connection</p> <p>2-wire connection: Close K will start up Open K will stop</p>
⑪⑫	DC 4 ~ 20mA analog output	They indicate the current value of motor at real-time working. The 20mA is full-scale value and that is four times than rated current of nominal power of onlinerunning soft starter, while, we can connect a 4 ~ 20mA DC current meter to check. The max value of output load resistance is 300Ω.

Note: Please make sure that external terminals are in right connection; otherwise, the product may be damaged.

4.3 The communication interfaces

RJ-45 is the standard web line socket.
DB9 socket has RS485 and RS232 interfaces inside.

Please see the diagram 4.4

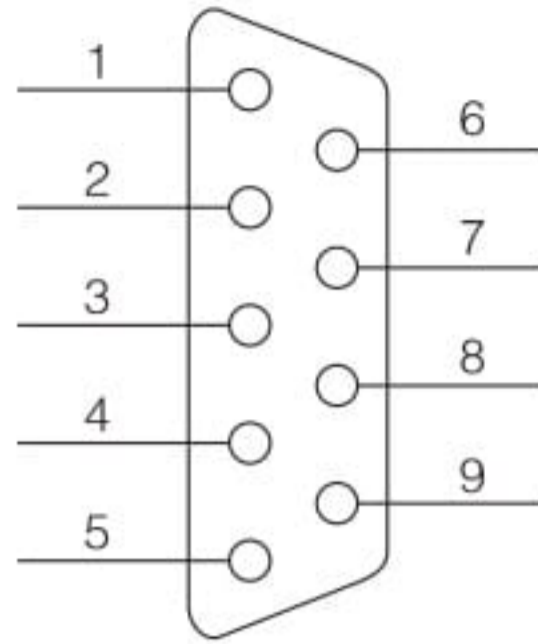

Diagram 4.4

- ① is RS485+
- ⑥ is RS485-
- ② is RS232 output.
- ③ is RS232 input.
- ④ is +5V output (limit-current is 50mA)
- ⑤ is earthed GND.
- ⑦ ⑧ ⑨ are empty.

The user can choose the following software:

- Computer collector distribution control communication software.
- Device Net interface card and communication.
- Device Net/Mod-bus/Profi-bus gateways.
- Others.

5. Control Panel and Operation

The online running soft starter has five kinds of working state; Ready, Run, Error, Starting and Stopping, the showing parameter is easy to understand and modify.

5.1 The operation of control panel



Diagram 5.1

- Open state: Please do not press the **RUN** key until the ready-lamp lights and show **READY**
- Time-delay state: When the ready-lamp or fault-lamp is shining, it means it is interval time delay; and when the display screen shows "dEXXX" and count down, that means starting time-delay.
- The **RUN** or **STOP RESET** key: In the process of starting, the panel shows "XXXX" that is the value of start-up current. At this time only key is valid. And the lamps of ready, Run and Error are all dark, and you can't come into the "Set Menu" and "Help Menu" state. While, in the process of stopping, the panel shows "XXXX" that is the value of motor current. At this time, only **RUN** key is valid, and the lamps of Ready, Run and Error are all dark, and you can't come into the "Set Menu" and "Help Menu" state. The **STOP RESET** key also has reset function.
- The **SET** key: Press **SET** key to enter the "Set Menu" and panel shows FX:XXX. Please press **SET** key again and Colon is shining, then you can change the parameters after the colon you need. If you want to save the parameter change, please press **PRG** key. If you do not want to save, please press the **SET** key until the colon stops shining, then the parameters recover. Having finished the above operation, please press the **PRG** key to exit or press **STOP RESET** key to exit directly.
- The **PRG** key: Under non-Set State, press the **PRG** key to enter "Help Menu" and the panel shows HX: XXX. When you finish reading the "Help Menu", you can press **PRG** key again or **STOP RESET** key to exit. Under Set State, This key can save parameters, and press again can exit set state.
- The "UP" **▲** and "DOWN" **▼** key: In "Set Menu", when the colon is not shining, you can press these two keys to select the Function Code; When colon is shining, you can press these two keys to change parameters. It is the same as the operation in "Help Menu". When the Pass-by -lamp is lighting and the display Screen shows AXXX which means the operation current value of motor, now you can press "UP" or "DOWN" key and the screen will display PXXXX or HXXXX. (PXXXX means the apparent power of motor; HXXXX means the over-load heat balance coefficient, if this value is more than 100%, the screen shows Error08, that means online running soft starter is at state of over-load protection.)

5.2 Parameters set and explanation

The explanation for "Parameter-set" codes.

F0 Initial voltage	Setting range	30-70%	Default	30%
	This code can be used when the starting mode is set as "Voltage ramp to start", and if the motor load is heavy, please set F0=40%, or higher a little. Under "Limit-current" mode ,the F0 value will be fixed as 40%.			
F1 Soft starting time	Setting range	2-60s	Default	16s
	It is used to set longest soft starting process time, and soft starting time maybe shorter for different load. It is invalid under "Limit-Current" starting mode.			
F2 Soft stopping time	Setting range	0-60s	Default	0s
	If the code set as "0", the motor will free stop. One soft starter for 2 motor, this code should set "0".			
F3 Start-up time delay	Setting range	0-999s	Default	0s
	Delay is with countdown mode; If set as "0", the starter will start up the motor immediately.			
F4 * Programming time-delay	Setting range	0-999s	Default	0s
	This code is used to set delay time of ③ & ④ terminals output. Set "0" immediately close. (Please refer to FE for details)			
F5 Start-up current limited value	Setting range	50~500%	Default	400%
	It is used when the starting mode is "current limit", and the value will be fixed as 400% when the starting mode is "Voltage ramp to start"			
F6 * Maximum current of soft starter	Setting range	50~200%	Default	100%
	The "50 ~ 200%" is basic on the nominal current of motor. If the set value of this code over 200%,the online running soft starter will reverse to overheat protection.			
F7 Lower voltage protection	Setting range	40~90%	Default	80%
	When the working voltage is under the voltage range(80%),the online running soft starter will be low voltage protection			
F8 Over voltage protection	Setting range	100~130%	Default	120%
	When the working voltage is over the voltage range(120%),the online running soft starter will be over voltage protection			
F9 Modes of starting	Setting range	0~5	Default	1
	0: Limit-current to start 1: Voltage ramp start 2: Torque control + limit current 3: Torque control + voltage ramp 4: Current ramp start 5: Double closed loop			

FA Protection Level	Setting range	0~4	Default	4
	0. Primary protection 1. Light-load protection 2. Standard protection 3. Heavy-load protection 4. The superior level protection			
FB Operation control mode	Setting range	0~7	Default	1
	0: Run by keypad 1: Run by keypad and terminal 2: Run by terminal 3: Run by terminal and RS485 4: Run by keypad, terminal and RS485 5: Run by keypad and RS485 6: Run by RS485 7: Inhibit start up or stop			
FC Parameter revise	Setting range	0~2	Default	1
	0: Parameter revise prohibit; 1: Partial parameter revise prohibit; 2: All parameter allow revising.			
FD * Communication address	Setting range	0~63	Default	0
	Many online running soft starters connect with upper computer.			
FE* Programming output	Setting range	0~19	Default	6
	Setting the detailed in Item 5.3			
FF* Soft-stopping limited current	Setting range	20~100%	Default	80%
	Setting the detailed in Item 7.3			
FP Motor rated current	Setting range	---	Default	Rated value
	"The rated current of motor" is the same as the motor nominal current. If your motor rated power is much lower than online running soft starter, please revise the FP same as motor rated current. And then online running soft starter can protect small KW motor. If you meet Error 05, please change FA=2.			
FL * 3 phase balance valid	Setting range	0~1	Default	1
	0: Invalid 1: Valid			

FM *	Setting range	50~150%	Default	100%
Current coefficient	Showing current slants high, to set coefficient down; Lower conversely			
FN *	Setting range	50~150%	Default	100%
voltage coefficient	Showing voltage slants high, to set coefficient down; lower conversely			

Note:

- F6 the "Max working current", is basic on the value of FP (nominal current of motor).
- If you have no any operation for 2 minutes after you come into the "set" state, online running soft starter will exit from "set" state.
- You can not set any parameters in the process of starting or stopping.
- If you press the  key to power on online running soft starter, all parameters will recover to default setting except FE code. When FC=1, these parameters with "*" is prohibited to revise. When FC=2, all parameters can be revised.

5.3 Parameters code function explanation

The parameter Fb is used to set the control ways of online running soft starter; as the following form:

Numerical value	0	1	2	3	4	5	6	7
Keypad	1	1	0	0	1	1	0	0
External terminal control	0	1	1	1	1	0	0	0
RS485 Communication	0	0	0	1	1	1	1	0

Note: In the above form, "1" is allowing, "0" is forbidding. For example, If you press keypad "RUN", and meet Error14, please set Fb=0. And then online running soft starter can be run by keypad.

If the "External Control" is allowing, you must contact a normally closed switch button between the terminal ⑦ ⑧ and terminal ⑩, otherwise the online running soft starter can't start-up the motor and show "Error01/Error16"

The parameter FE is use to setting the way of ③ & ④ programmable relay output, As the following form:

The number setting by FE	The moment of programmable relay output
0(10)	When sending the order of starting, the program output
1(11)	When beginning to start, the program output
2(12)	When at the start of bypass operation, the program output
3(13)	When sending the order of stopping, the program output
4(14)	When finishing the operation of stopping, the program output



If users need programmable relay output time delay, the time can be setting by parameter F4.

- When the FE is setting as 5~9(15~19), the terminal ③ & ④ will display the state of programmable relay output. As the following form:



The number setting by FE	The state of programmable relay output
5(15)	Error state
6(16)	Working state
7(17)	Ready state
8(18)	Starting state
9(19)	By-pass operation state

- The state of programmable relay output is used to show the working state of online running soft starter, and under this way, the **F4** setting delay time is invalid;
- The default setting of **FE** code is "7" showing the ready state of online running soft starter and at this state the motor can be started up;
- When the **FE** code is "5" outputting error state of motor, Terminal ③④ can output fault such as:(Error05 , Error06, Error07, Error08,Error12, Error14). This will not affect the function of ⑤⑥ error output terminals.
- When **FE** >9, the programmable output will be "reverse phase output", (**Normal open will reverse to normal close**).
- When **FE** =0, all parameters cannot be revised. And when **FC**=1, (F4, F6, Fd, FE, FF, FU)cannot be revised. When **FC**=2, all parameters can be revised.

5.4 Helping message and explanation

When the product is not starting or stopping ,or not at the "set" state, you can press  key and come into helping menu ,then press the "UP" or "DOWN" key to choose the help message. Please press  or  key to return.Helping message Form

Message displayed	Explanation
AC:380V	That is the 3-phase power voltage is AC 380V.
015A-380V	That is the specification is AC 380V, 50Hz, 30A.
H1:ERROR 01	The fault message Error 01 that happened at the last time.
...
H9:ERROR 00	It says no fault happened.
Ver 6.0	It says the software of the products is Ver 6.0
L 0000	0000 is times of successful soft starting
T-run 00s	00 is last soft starting time
Note: The message H1 ~ H9 displayed means 9 faults records that happened lately.	

- Not in state of soft starting and stopping, and not in setting state, to press  key to enter helping menu, and press "UP" or "DOWN" key to choose helping information.
- Under state of helping, to press  key or  key to quit helping menu.

6. Protection Functions and Directions

We make our online running soft starters have all kinds of protection functions to protect the safety of online running soft starter and the motor. Please choose the correct protection Class and parameters according to your application conditions!

Over-heat protection: When online running soft starter inside temperature is up to $80^{\circ}\text{C} \pm 5^{\circ}\text{C}$, the starter will turn to over-heat protection, when be down to 55°C , this protection removes.

- Input less-phase protection: The delayed time $< 3\text{s}$
- Output less-phase protection: The delayed time $< 3\text{s}$
- Three-phase unbalance protection: The delayed time $< 3\text{s}$, when the difference of current among three phrases is more than $50\% \pm 10\%$, the protection be valid.
- Starting over-current protection time: The diagram of over current 5 times of **F6** set rated working current is just as diagram 6.1.
- Working over-load protection time: The starter will be in inverse time thermal protection on. Base of the Max working current of motor (Set by **F6**), (The diagram 6.1 show)
- Low voltage protection delay time: When power voltage is less than 40%, the protection delayed time $< 0.5\text{s}$; When power voltage is less than 80%, the protection delayed time $< 3\text{s}$.
- Over-voltage protection delay time: When power voltage is more than 140%, the protection delayed time $< 0.5\text{s}$; When power voltage is more than 120%, the protection delayed time $< 3\text{s}$.
- Loads short-circuit protection delay time: The protection delayed time $< 0.1\text{s}$.

6.1 Protection classes and explanation

According different usage conditions, S6100 series online running soft starter has five protection classes, as following:

0. Primary protection
 1. Light-load protection
 2. Standard protection
 3. Heavy-load protection
 4. The superior protection
- Primary protection includes the protection functions of overheat, short circuit, and input default phase protection and prohibit external instantaneous stop terminal. Which is proper urgently startup conditions, such as fire pump.
 - The protections of light load, standard and heavy-load have the overall protection function of soft starter. The difference among them is protection level of overload and over current. See the diagram of 6.1.
 - Under the superior protection, the soft starter has a higher protection level.
 - The protection classes and the time of heat protection as (diagram 6.1)

FA code	0:Basic protection	1:Light-load protection			2:Standard protection			3:Heavy-load protection			4:Superior protection			Note
The grade of overload protection	No	2 grade			10 grade			20 grade			10 grade			Standard of IEC60947-4-2
The grade of over-current protection	No	3 Second			15 Second			30 Second			15 Second			The 5 times of F6 current
Overload drop-away time	The multiple to the rated current	3	4	5	3	4	5	3	4	5	3	4	5	They are the typical values
	Drop-away time (S)	4.5	2.2	1.5	23	12	7.5	46	23	15	23	12	7.5	

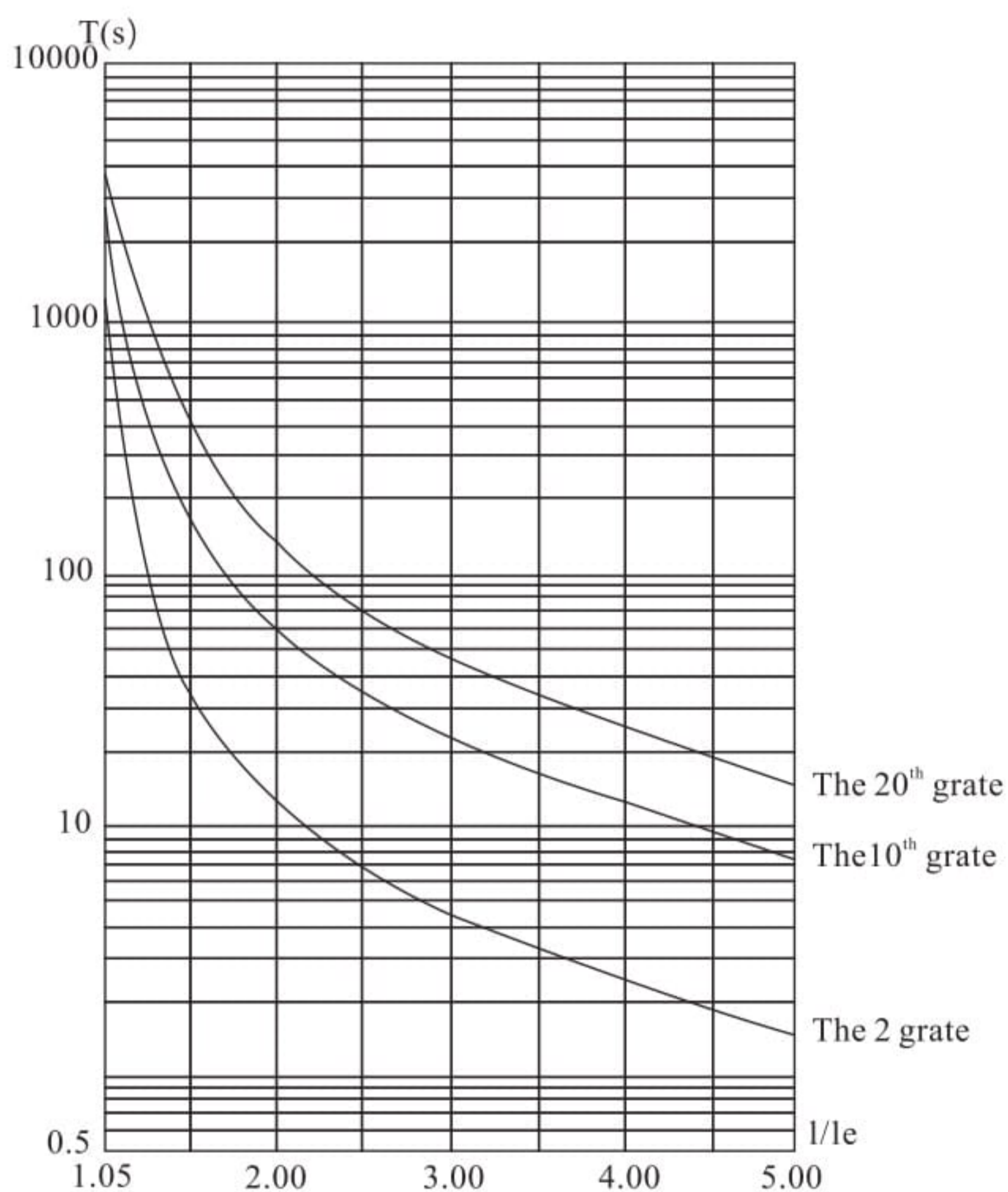

Diagram 6.1 (IEC60947-4-2 standard) Motor heat protection curve (overload drop-away time)

Remark:

- **FP** set value should be same as motor nameplate rated current.



The **FP** set value should not be less than 20% of online running soft starter rated current, otherwise the overheat protection will be useless because of big tolerance.

7. Test Run and Application

Please do some examinations before test running as following:

- Whether the rated power of online running soft starter is matched with the Motor.
- Whether the insulation of motor meets requirement.
- Whether the main circuit connection of input and output is correct.
- Whether all the screws of terminals are twisted tightly.

7.1 Power on to test running

- After Power on, please do not disassemble the online running soft starter cover that is dangerous!
- Power on, soft starter displays Ready, and the Ready is light, then you can press  key to start.
- Set **FP** be same as motor nameplate rated current.
- After started the motor, you should examine whether the motor running direction is correct, or whether runs normally. If not, you can press  key or cut off the power to stop running.
- If the soft starter starting state is not satisfied. Please see the detailed explanation at 7.2: the starting mode and application
- If the start torque is not enough, you can change the starting voltage (when the starting mode is voltage control) or the certain current value (when the mode is current control) to improve start torque.
- Do not open the face cover in case of electric shock.
- If there is any abnormal voice, smoke or taste, please cut off power as soon as fast, and check the reason.
- When the starter power on or be in starting, the error lamp is lighting and screen displays "Err??", at this time, you can check diagram 7.1 to find out reason.
- Press  key or external stop button can reset the error state.

Note: When ambient temperature is less than -10°C , the starter should be power on to preheat for 30 minute, and then to start.

Error Code	Error 00	Fault Type	The fault is removed
Reason and solution	Any faults are removed, such as low-voltage, over-voltage, over-heat. Now the Ready-lamp is lighting and you can start the motor.		
Error Code	Error 01	Fault Type	The external instantaneous stop terminal is open
Reason and solution	Please connect the external instantaneous stop terminal (terminal ⑦) and stop terminal 8 with the public terminal (terminal ⑩) together.		
Error Code	Error 02	Fault Type	The soft starter is over heat
Reason and solution	The soft starter is started too frequently, or the soft starter rated current is smaller than motor, or motor is heavy over load.		
Error Code	Error 03	Fault Type	The starting time is over long, which is longer than 60s.
Reason and solution	The starter parameter is set wrong; or the motor load is heavy, or voltage transformer capacity is not enough; or power supply cable is too long. If soft starter capacity is enough and load is heavy fan or pump, please set FU to 10 or 15 second.		

Error Code	Error 04	Fault Type	Input phase failure
Reason and solution	Please check whether the input circuit connections, by pass contactor and the controlled silicon is open or whether the thyristor wire is not connected.		
Error Code	Error 05	Fault Type	Output phase-failure
Reason and solution	Please check whether the output circuit connection, bypass contactor and the controlled silicon are short circuit, or whether the thyristor wire is connected well ; The power supply should connect to R,S,T, and bypass contactor should connect with L1,L2,L3; If motor KW is much smaller than soft starter, please set parameter FA=2.		
Error Code	Error 06	Fault Type	Three-phase unbalance
Reason and solution	Please check the input three-phase power voltage is balance or not , and check the motor 3phase is abnormal. Or set parameter FC=2 and E1=0.		
Error Code	Error 07	Fault Type	Starting over current
Reason and solution	Overload, or the motor is not matched with the soft starter.		
Error Code	Error 08	Fault Type	Running over load
Reason and solution	Overload or the $F5$ code is set wrong.		
Error Code	Error 09	Fault Type	Low voltage
Reason and solution	Please check the voltage of input power or the F7 item is set wrong.		
Error Code	Error 10	Fault Type	Over voltage
Reason and solution	Please check the voltage of input power or the F8 item is set wrong.		
Error Code	Error 11	Fault Type	The parameters are set wrong
Reason and solution	Please change the parameter correctly, or you can press the  key to power on the starter again to recovery the default setting.		
Error Code	Error 12	Fault Type	Load short circuit
Reason and solution	Check load and the controlled silicon is short circuit or overload.		
Error Code	Error 13	Fault Type	The wiring of automatic Re-start is wrong
Reason and solution	The external terminals is not connected according the 2-wire way.		
Error Code	Error 14	Fault Type	The wiring of external terminal is wrong
Reason and solution	Change $Fb = 0$,When external control mode is allowing, the external stop terminal is open, and soft starter cannot start.		

Error Code	Error 15	Fault Type	Motor less load
Reason and solution	Please match the appropriate motor.		
Error Code	Error 16	Fault Type	⑧,⑩ terminal open circuit
Reason and solution	Please check and connect⑧,⑩.		
Note: When the motor starts successfully, ① and ② will close to suck by pass contactor running. At this time, if the contactor is not closed, the motor will stop running, so you can check whether the wiring of the bypass contactor is right.			

7.2 The starting mode and application

The S6100 series soft starter has six starting modes for the user to select according the motor and load equipments.

7.2.1 Current-limit to start

(The F9 code is set as "0") Diagram 7.1 shows the waveform of motor current. I_1 is the starting limit-current preset value. When starting, the output voltage rises quickly till the motor current up to I_1 value and not beyond this value. The motor runs steadily in pace with the rising of output voltage, and when the motor runs to be the rated speed, the output current will have a quick-drop and down to the motor rated current (I_e value), then the bypass contactor is working, the starting process finished.

Note: When motor load is too light or I_1 preset value is too high, the max current of starting may can not reach I_1 value. This starting mode fits for the conditions which requires strict current limit of starting.

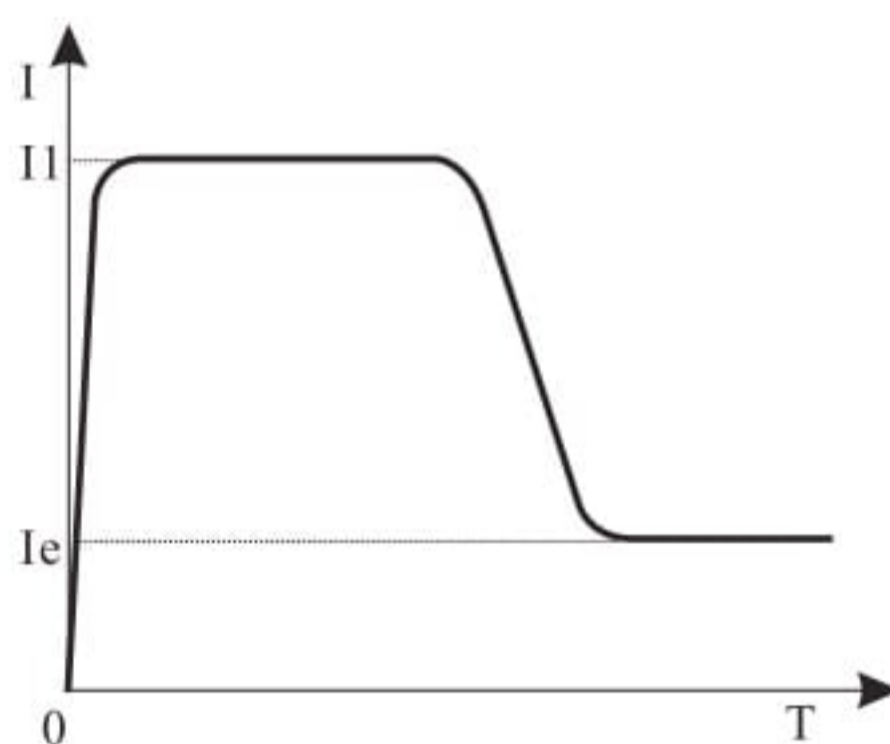

Diagram 7.1

7.2.2 Voltage ramp to start

(The F9 code is set as "1") Diagram 7.2 shows the output voltage waveform. In the diagram, the U_1 is the initial voltage value of starting. When starting, if the motor current is not more 400% than the rated current, the output voltage of soft starter will rapidly rise to U_1 , and the output voltage rises gradually to the rated voltage (U_e), and the motor gradually increase and until running at rated voltage and speed, and then the bypass contactor closed, the starting process finished.

Starting time "T" is obtained in the standard experiment under the condition of soft starter with standard load. And soft starter takes this control parameters as a benchmark, smooth acceleration by controlling the output voltage to motor starting process to complete, not mechanically controlled time "T" and regardless smooth of whether the

motor speed. In view of this, when the load is lighter, starting time are often less than the set starting time, as long as can smooth starter is normal

In general, the voltage ramp is generally used mode; it is suitable for requiring higher starting stability without strictly current limitation case.

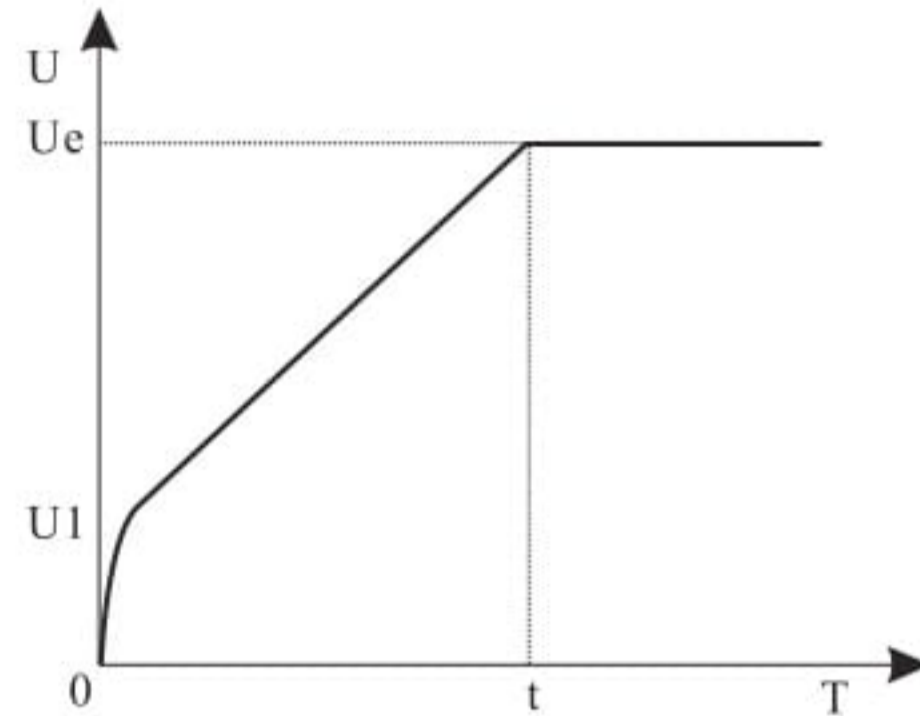

Diagram 7.2

Note: "T" is the automatic detecting starting time according to load. It will be less than set time when the load equipments are light; this starting mode fits for the common occasions where the motor need to be started smoothly.

7.2.3 Torque control + current limit or + voltage ramp to start

(The F9 code is set as "2" or "3") Diagram 7.3 and 7.4 shows the output changing waveform of torque control starting mode. When the static friction force of heavy load is too stronger to start the motor, user can use this starting mode. At first state of starting, the motor needs a higher voltage to conquer the static friction force of heavy load, and then starts with current-limit or voltage ramp mode to start the heavy motor.

Note: This mode will cause big-current shock to the motor, so if the voltage ramp or current limit starting mode can startup the motor, it is better not to use this torque control mode to start.

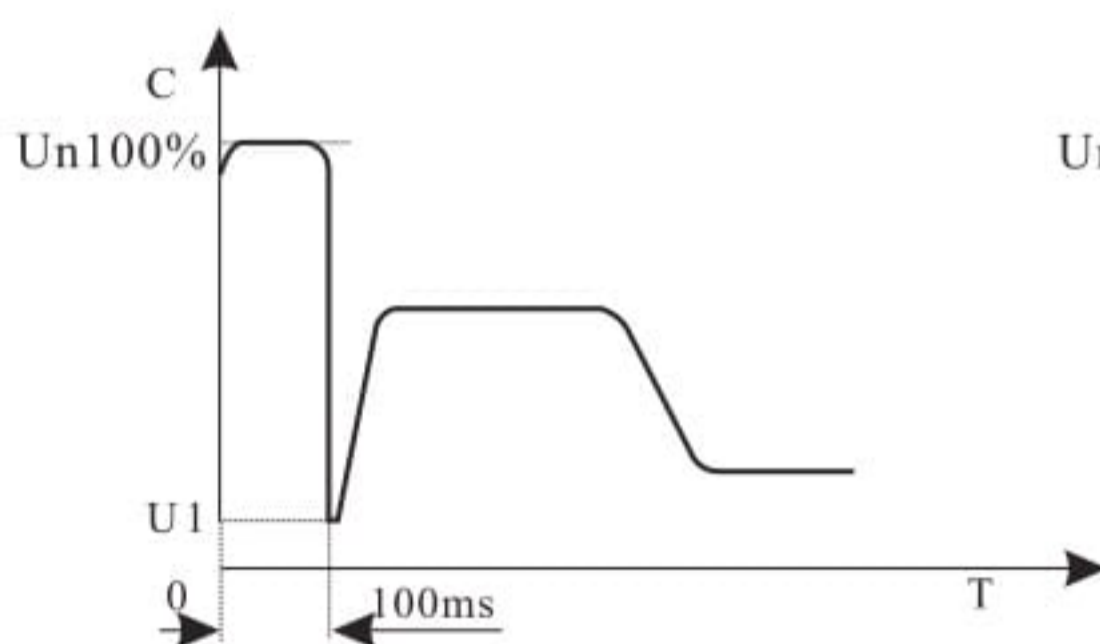

Diagram 7.3

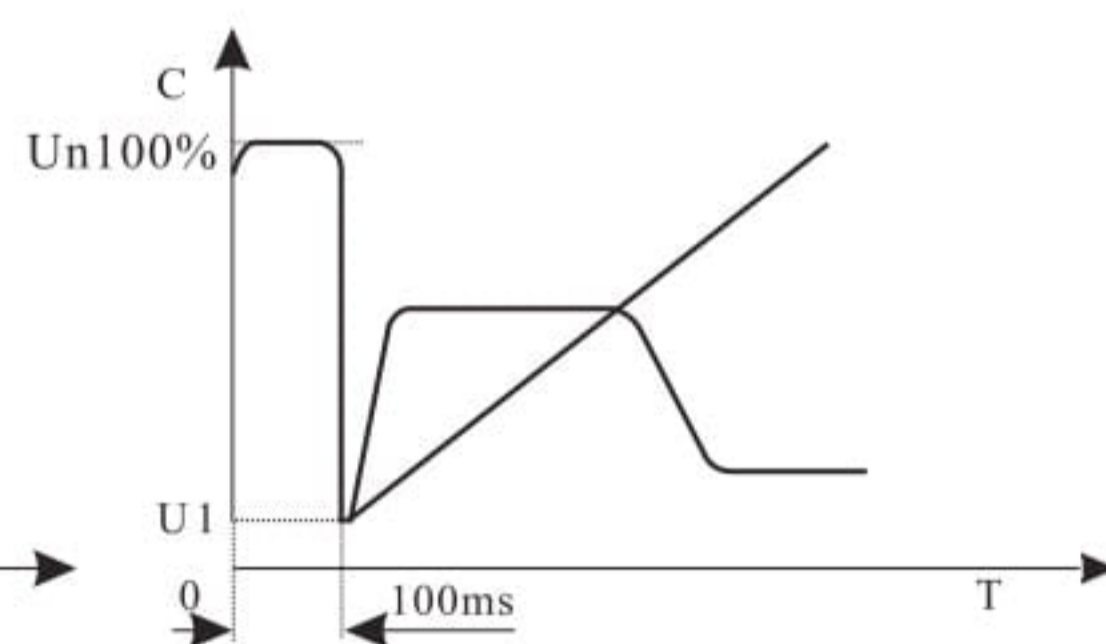

Diagram 7.4

7.2.4 Current ramp to start

(The F9 code is set as "4") Diagram 7.5 shows the output current waveform. The I1 in the diagram is current value preset by F5 code, and T1 is time value present by F1 code. This starting mode has very stronger speed-up ability and is suit for the bipolar motors, and it can reduce the starting time.

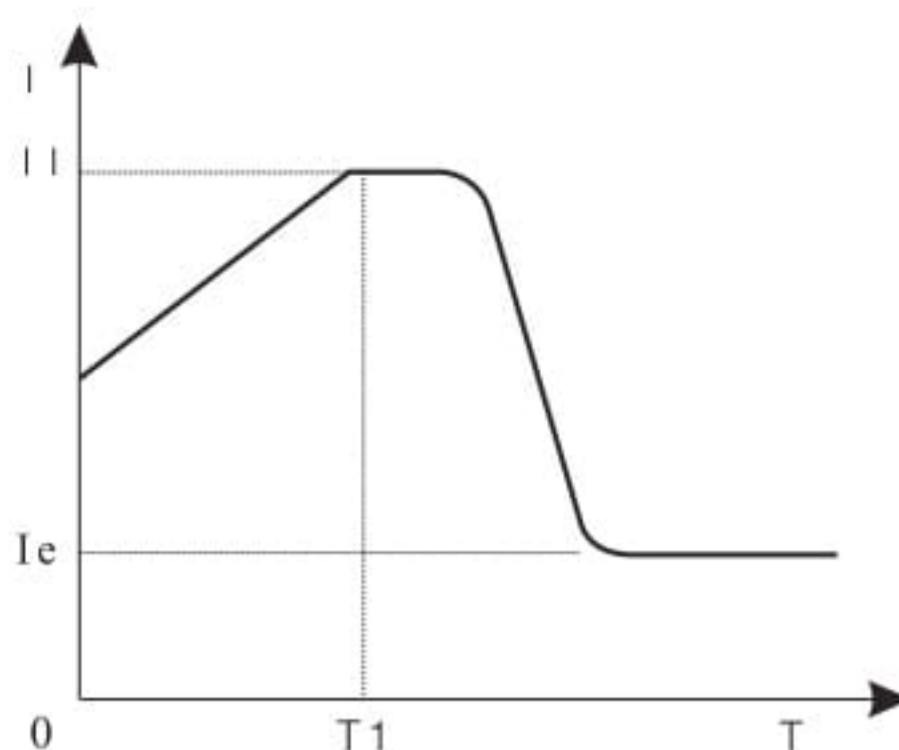

Diagram 7.5

7.2.5 Voltage current-limiting double closed-loop start

(Both voltage ramp and current limit) to start (The F9 items set as "5"). This starting mode uses voltage ramp and current limit double closed loop circuit; it is a composite starting mode. The output voltage waveform is changed as different motor and the load equipments. This mode fits for smooth starting and strictly current limit occasions.

7.3 The stopping mode and application

The soft starter has two stopping modes; those are Soft-stopping mode and Free-stopping mode.

7.3.1 Soft-stopping Mode

(The F2 item is not set as "0") When using this mode to stop the motor, the power supply of motor will be transferred from the bypass contactor to the controlled silicon of soft starter, and the output voltage of starter will be reduced gradually so that the running speed of motor can be cut down smoothly avoid mechanical shock. The output ending voltage is the same as the starting initial voltage. Soft-stopping mode can reduce or remove the surge of the loading equipments such as the water pump.

You can set the soft-stopping current limit value through the FF code to reduce the high current shock to the motor when stopping. This current limit value is percentage of F5 .

7.3.2 Free-stopping Mode

(The F2 code is set as "0") When using this mode to stop the motor, the soft starter will cut off the connection to the bypass contactor and forbid the controlled silicon output voltage after receiving stopping command. The motor stops gradually with its inertia. One soft start connecting with two motors must use this free stopping mode. Generally, if the soft stopping mode is not necessary, please choose the free stopping mode to prolong the service life of soft starter. This mode completely forbids the instantaneous output; avoid instantaneous high current shock to the motor of specially applying.

7.4 Special application

- **In parallel the starting of the motors:** If the motors total power is less than 80% of soft starter, the motors can be parallel connection. But at this time should be also provides for each motor thermal protection device.
- **Double speed motor:** Motor soft starter can cooperate with double speed motor starting, must go through demagnetization delay period before change from low speed to high speed, to avoid anti-phase current generated between the lines and motor.
- **Too long cable:** f the cable is too long, the cable voltage drop will be high, and that will increase current loss and reduce starting torque, so please use big KW soft starter and motor.

- **Soft starter parallel connected with one power-line:** If several soft starter parallel installed in the one power line, the input line reactor should be installed in the middle of the transformer and the soft starter circuit. Reactor should be installed at each line input side between circuit breaker and soft starter.
- **The application of surge protection device (SPD):** The surge protection device should be considered to installed in the application case, where is easily caused trouble by lightning or other reasons, such as over voltage, over-current, surge interference. Please refer to SPD related documents for details.

7.5 Application examples

The parameters of the different loads are different, please refer to diagram 7.2.

The loading	Voltage ramp starting time(s)	Voltage ramp stopping time(s)	Initial voltage	Voltage ramp (current limit)	Current limit to start
Ball mill machine	20	6	60%	400%	350%
Fan	26	4	30%	400%	350%
Centrifugal	16	20	40%	400%	250%
Piston compressor	16	4	40%	400%	300%
hoister	16	10	60%	400%	350%
Stirring machine	16	2	50%	400%	300%
Breaker	16	10	50%	400%	350%
Screw compressor	16	2	40%	400%	300%
Rotating conveyor	20	10	40%	400%	200%
Light load	16	2	30%	400%	300%
Convey belt	20	10	40%	400%	250%
Heat pump	16	20	40%	400%	300%

8. Online Running Soft Starter Cabinet

Online running soft start cabinet is mainly used for all kinds of high power motor startup, using the soft start to replace the traditional starting way to realize smooth starting, reduce the starting current, reduce larger electric current of motor starting mechanical shock, and reduce the impact on the power grid, improve power quality and save energy. Using protection of locked-rotor and fast responsibility to avoid motor overheating or burning caused by mechanical failure or locked-rotor fault, reduce the voltage drop caused by large starting current which affect other electrical appliances, reduce wear and prolong the service life of the motor, saving machinery maintenance.

8.1 Product Function

Online running soft start cabinet adapts various occasions. According to customer requirements to single motor startup, more machines startup at the same time, many motors sequence delay startup function.

- Soft stop function: can choose free stopping or soft stopping.
- It can protect own system and the bypass contactor, and has 12 kinds of protections for motor. Such as short circuit protection, overload protection, over current, input or output phase lost.
- With a variety of control modes. It can be controlled by keypad, also can be remote controlled, and also can be inter-locked with other equipments; Equipped with communication interface (optional), easy to realize automatic control. Current and voltage double closed loop control, it is suitable for all kinds of motor. Starting current and voltage both can be adjusted
- LCD screen for English language displaying interface, parameter setting, convenient inquiry, working state real time displaying.
- Soft starting slope and maintain time adjustable, can adapt to low voltage or small transformer capacity occasion.

The usage condition

- **Power Supply:** City grid power, self-provided power, diesel oil dynamotor, 3-phase alternating current 220V/380V/480V/660V \pm 15%, 50Hz or 60Hz. The power capacity of the soft start must meet the motor starting requirement.
- The power supply capacity must satisfy the requirement of the soft starter for motor starting.
- **Matched Motor:** Motor should be three phase squirrel asynchronous motor, and its power capacity must be matched with soft starters.
- **Starting Frequency:** The starting time is according to the loading equipments, less than 20 times per hour with full load.
- **Cooling Mode:** fan compelled wind cooling.
- **Protective Grade:** IP20
- **Environment Conditions:** when altitude is less than 1000m, the temperature of the environment should be between -25 °C ~ 45°C, relative humidity should be less than 90% RH, no vapor, no flammable, volatile, corrosive gas. No electric dirt, indoor installation, ventilated, vibration is less 0.5G. Soft starter should de-rate power above altitude of 2000 meters.

8.2 The structure and installation method

By floor vertical installation, can be installed above the groove, the power cables and control cables introduced from groove into control cabinet. The cabinet body used angle steel framework, control cabinet front and back can open the door, the cabinet appearance adopted powder painting processing, and its model and size is in the following table.

Model	Voltage	Power	Current	External Dimensions(mm)		
	(V)	(KW)	(A)	W	D	H
AST6100-S1-7.5-Z	380V-480V	7.5	15	150	202	330
AST6100-S1-11-Z	380V-480V	11	23	150	202	330
AST6100-S1-15-Z	380V-480V	15	30	150	202	330
AST6100-S1-18.5-Z	380V-480V	18.5	37	150	202	330
AST6100-S1-22-Z	380V-480V	22	45	150	202	330
AST6100-S1-30-Z	380V-480V	30	60	150	202	330
AST6100-S1-37-Z	380V-480V	37	75	150	202	330
AST6100-S1-45-Z	380V-480V	45	90	150	202	330
AST6100-S1-55-Z	380V-480V	55	110	150	202	330
AST6100-S1-75-Z	380V-480V	75	150	172	220	355
AST6100-S1-90-Z	380V-480V	90	180	210	253	394
AST6100-S1-115-Z	380V-480V	115	230	210	253	394
AST6100-S1-132-Z	380V-480V	132	260	490	295	608
AST6100-S1-160-Z	380V-480V	160	320	490	295	608
AST6100-S1-185-Z	380V-480V	185	370	490	295	608
AST6100-S1-200-Z	380V-480V	200	400	490	295	608
AST6100-S1-220-Z	380V-480V	220	450	490	295	608
AST6100-S1-250-Z	380V-480V	250	500	490	295	608
AST6100-S1-280-Z	380V-480V	280	560	490	295	608
AST6100-S1-320-Z	380V-480V	320	630	490	295	608
AST6100-S1-350-Z	380V-480V	350	700	680	408	840
AST6100-S1-400-Z	380V-480V	400	800	680	408	840
AST6100-S1-450-Z	380V-480V	450	900	680	408	840
AST6100-S1-500-Z	380V-480V	500	1000	680	408	840
AST6100-S1-630-Z	380V-480V	630	1200	680	408	840

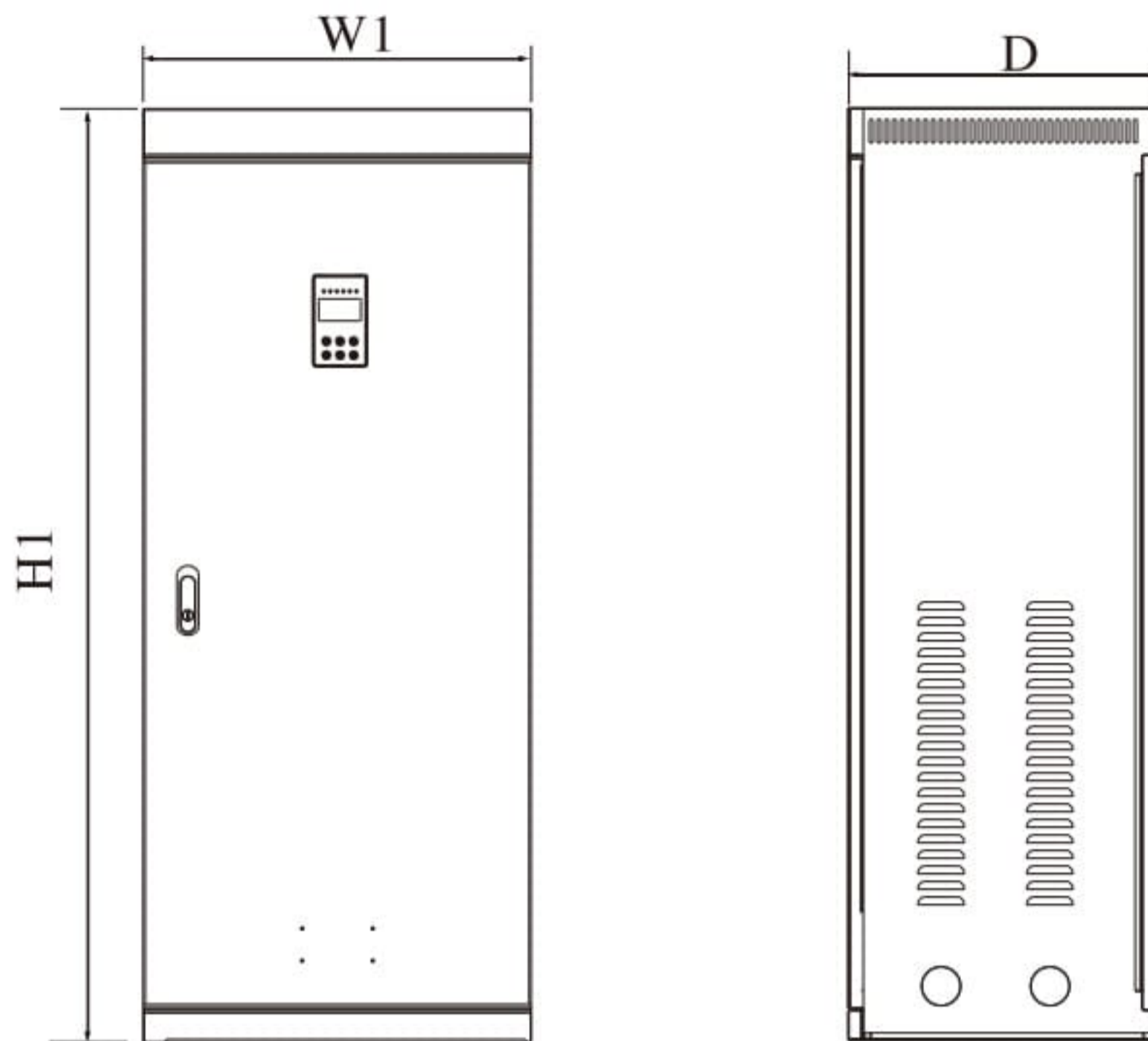

8.3 The operation of control panel

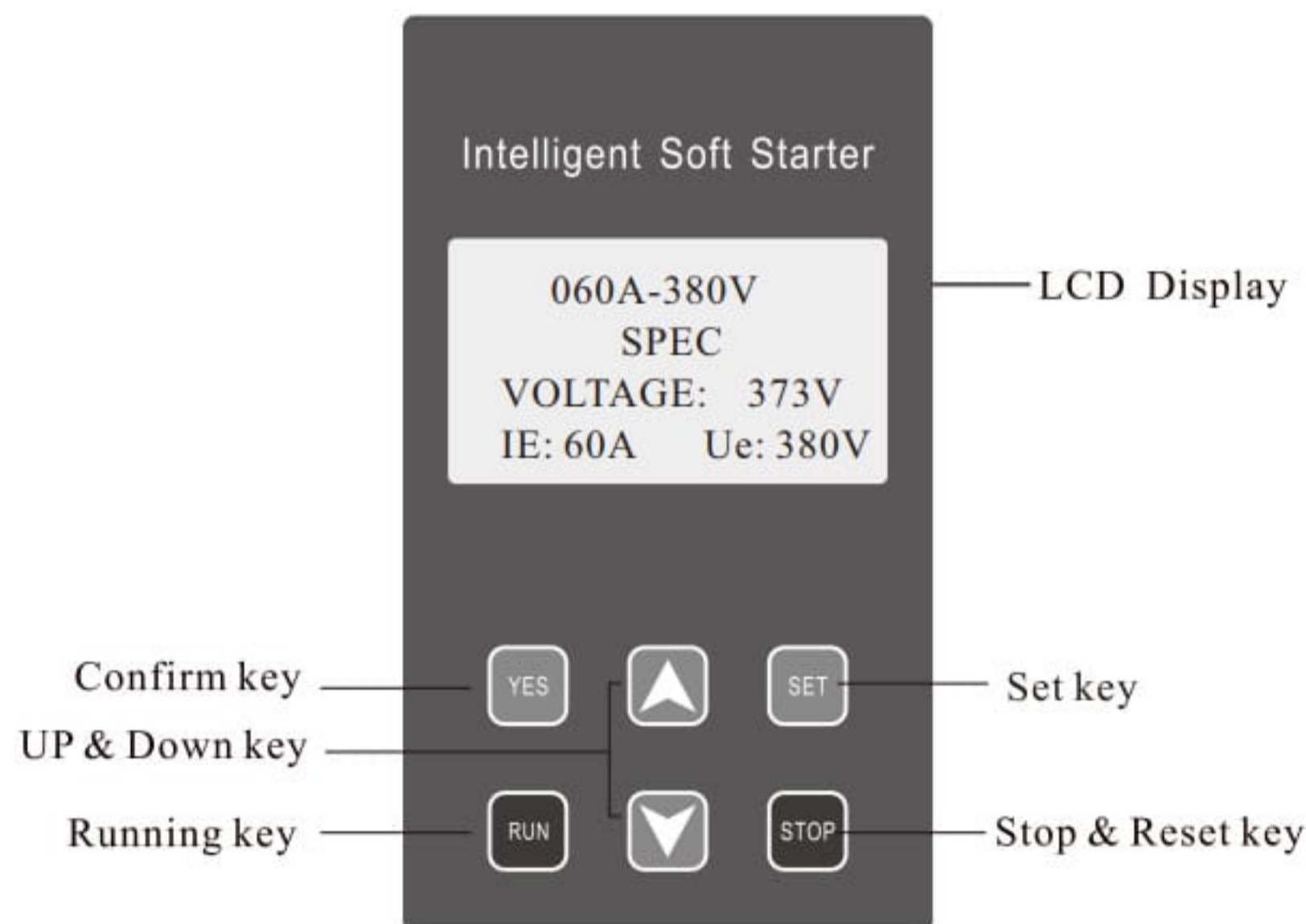

- Power on : Will show "READY", press **RUN** key can soft start motor The state "READY" means soft starter is ready for starting.

The keypad key specification:

- **RUN** key and **STOP&RSET** key: In the soft starting process, keypad will show "A:***" displaying motor current, at this moment, only **STOP&RSET** key is valid, and cannot enter menu of parameter setting and helping. In the soft stopping process, the keypad will show "A:***", displaying motor current, at this moment, only **RUN** key is valid, and cannot enter menu of parameter setting and helping, **STOP&RSET** key also has function of fault reset.

SET key: under non-helping state, to press **SET** key enter setting menu, displaying initial voltage F0:30%, and press **SET** key again, the colon behind F0 flashing, means the parameter behind colon is revisable, and press **UP** key or **DOWN** key to change parameter. And then press **YES** key to save, the screen will show "GOOD" and ring two, means parameter saved, and then quit. If you do not want to save new parameter, to press **SET** key, the colon stop flashing and recover old parameter, and to press **YES** key to quit, also can directly go back to main menu by pressing **STOP&RSET** key.

- **YES** key: Under non-setting state, press **YES** key to enter helping menu, displaying power voltage "AC:XXXXV", and press **YES** key to quit, and also can press **STOP&RSET** key quit. Under setting state, to press **YES** key to save new parameter and quit setting state.
- **UP** key and **DOWN** key: Under setting menu, when the colon no-flashing to press **UP** key or **DOWN** key can change parameter code, when colon flashing: **UP** key or **DOWN** key to change this parameter value; pressing **UP** key or **DOWN** key over 1 second, the parameter value will rapidly change. Under helping menu to press **UP** key or **DOWN** key can change function code and helping information. When the soft starter is starting, and do not enter setting and helping menu, the keypad will display motor current : "A:*** ", at this time to press **UP** key or **DOWN** key, can check apparent power "XXX.XKW" or over load ratio "XXX.X%", when the overload ratio over 100%, starter will stop and alarm over load, the keypad displaying "Error 8".
- There will be a sound when pressing key is valid, no sound means this key is invalid under this state.
- when external control way use 3 wiring, the terminal start button and stop button is same function as keypad **RUN** key and **STOP&RSET**.
- Control keypad adopts super-strong anti-interference design, allowing the extending cable distance longer than 3 meters.

8.4 Operation procedures and cautions

Operation procedures:

- Be sure to read the manual, operation procedures and cautions before use soft starter.
- Before power on soft starter cabinet, please open the cabinet door, and switch on breaker, when the cabinet power indicator (red lamp) light, means cabinet has been power on, and soft starter is on ready state.
- Should check the motor wiring before startup.
- press the "start" button after confirmed, the operation indicator (green light) on, the motor starts to run.
- When press the "stop" button, the motor will free stopping (if preset soft stopping time, the motor will soft stopping), and the running indicator (green light) off.

Parameter setting:

- Parameters setting is same as online soft starter, please refer to the online soft starter parameter Settings on page 10.

Caution:

- Online soft start cabinet before work, must close the main power circuit breaker.
- When power or operation, the fault indicator (yellow light) on soft start cabinet, said malfunction for online soft start cabinet or motor with the load, should stop check the fault reason, after solved the fault to restart.

Soft starter MODBUS communication protocol

1.Modbus RTU communication protocol overview

1.1 Electrical Interface: RS485 half-duplex

Communication parameters: Baud rate 9600,8 data bits, no parity, a stop bit;

2.the control of soft starter: on, off, reset:

Control register address: 0001

The command format is as follows:

Address code	Function code	Register address	Command code	CRC check
1 byte	1 byte	2 byte	2 byte	2 byte

Address code: Local address

Function code: 06 (for writing register)

Register Address: 0001

There has 3 kind of commands:

0001H ----- start

0002H ----- stop

0004H ----- Reset

***** CRC is not manually entered, generated automatically by the program *****

Example: Start the soft starter at slave address 02, the controller sends 02

06 00 01 00 01 + CRC two bytes, if the command is normal, return to the

original code 02 06 00 01 00 01, whether soft starter can start normally need to check

the status of register, if there is a fault, it should be reset by sending 02 06 00 01 00 04

+ CRC two bytes.

2.3.2 Read status register

Address of status register:0002

Command format:

Address code: Local address

Function code: 03 (for reading register)

Register address: 0002

Number of read registers: 01 (read one register)

Address code	Function code	Register address	Read the number of registers	CRC check
1 byte	1 byte	2 byte	2 byte	2 byte

Example: Read Status Register Code

02 03 00 02 00 01+ (CRC)

The value returned by the soft starter
after sending the read status byte:

Address code	Function code	Read data bytes	Read the data content	CRC check
1 byte	1 byte	2 byte	2 byte	2 byte

Corresponding to read the data content:

Data content corresponding to reading:

Waiting for the state ----- 0000

Starting status ----- 0001

Operating status ----- 0002

Soft stop status ----- 0004

Fault status ----- 0008

If it is in starting, return code 02 03 02 00 01 + CRC

If the starter fails, return code 02 03 02 00 08 + CRC

2.3.3 40003 current average (Hex)

The data format is the same as read status register, only single byte read

Current percentage display or represent the actual current value Example: Read 02 soft starter current size

Send code: 02 03 00 03 00 01 + CRC If the current is 235A, return 02 03 02 00 EB + CRC

2.3.4 40004 Fault Code (Hex)

If it returns 02 03 02 00 04, it shows that the current input phase loss (fault code 04), please refer to the description of the fault;

Send code: 02 03 00 04 00 01

If it returns 02 03 02 00 04, it shows that the current input phase loss (fault code 04), please refer to the description of the fault;

2.3.5 Function Register

256-274 is the function register, the corresponding address is 0X100-0X111, the high byte is 1, the low byte address is 0X00-0X11, and the corresponding function code F0-FU, for example, address 0X109 corresponds to function code 09 (startup mode). These codes can be read and written, for example as follows:

Example 1: Read function code start current limit F5

02 03 01 05 00 01 + CRC Return Read the value of 05 function code. 02 03 02 01 5E + CRC

indicates the current limit is 350%

02 indicates the soft starter address

03 read

02 indicates the data byte read

01 5E indicates the returned data, hexadecimal, 015E indicates the decimal 350;

Example 2: read the output protection level FA

Send code 02 03 01 0A 00 01 + CRC

Return to read the value of 0A function code. 02 03 02 00 03 + CRC means the protection level is 3, 02 means soft starter address ,03 means read ,02 means read data byte

00 03 said the returned data is hexadecimal, decimal is also 3;

Example 3:

soft starter function code F5 (starting limit current) rewritten to 250%

Code 02 06 01 05 00 FA + CRC, return code 02 06 01 05 00 FA + CRC

If the return code 02 86 03 means that it can not be written, the starter may be running.

3 Abnormal response

Code	Name	instructions
01	Illegal function	soft starter do not support function code
02	Illegal data address	Illegal address can not be processed
03	Illegal data value	Received data can not be executed 1, the parameters exceed the space 2, the parameters can not be modified 3, the parameters can not be modified when running

3.1 Illegal function code 01

Master inquiry message format:

Slave address	Function code	Starting address High byte	Starting address Low byte	Register Number (high)	Register Number (high)	CRC correction
0x01	0x08	0x00	0x80	0x00	0x0D	

this protocol do not use 0x08 function code and slave read:

Slave address	Function code	Abnormal code	CRC correction
0x01	0x88	0x01	

3.2 Illegal data address 02

Master station inquiry message format:

Slave address	Function code	Starting address High byte	Starting address Low byte	Register Number (high)	Register Number (high)	CRC correction
0x01	0x04	0x01	0x80	0x00	0x07	

Slave address	Function code	Abnormal code	CRC correction
0x01	0x84	0x02	

3.3 Illegal data address 03

Master station inquiry message format :

Slave address	Function code	Starting address High byte	Starting address Low byte	Register Number (high)	Register Number (high)	CRC correction
0x01	0x04	0x00	0x80	0x01	0x80	

04 Function code register address failure and slaver replied

Slave address	Function code	Abnormal code	CRC correction
0x01	0x84	0x03	

4 Notice of using

1. Soft starter communication address ,rates and correction mode must be consistent with controller communication setting
2. If not receive corresponding data, check parameter setting and terminal connection
3. When Multiple soft starters in communications ,the last one should be connected with 120ohm resistor on AB terminal
4. When connecting with other MODBUS equipment, please connect as follows:

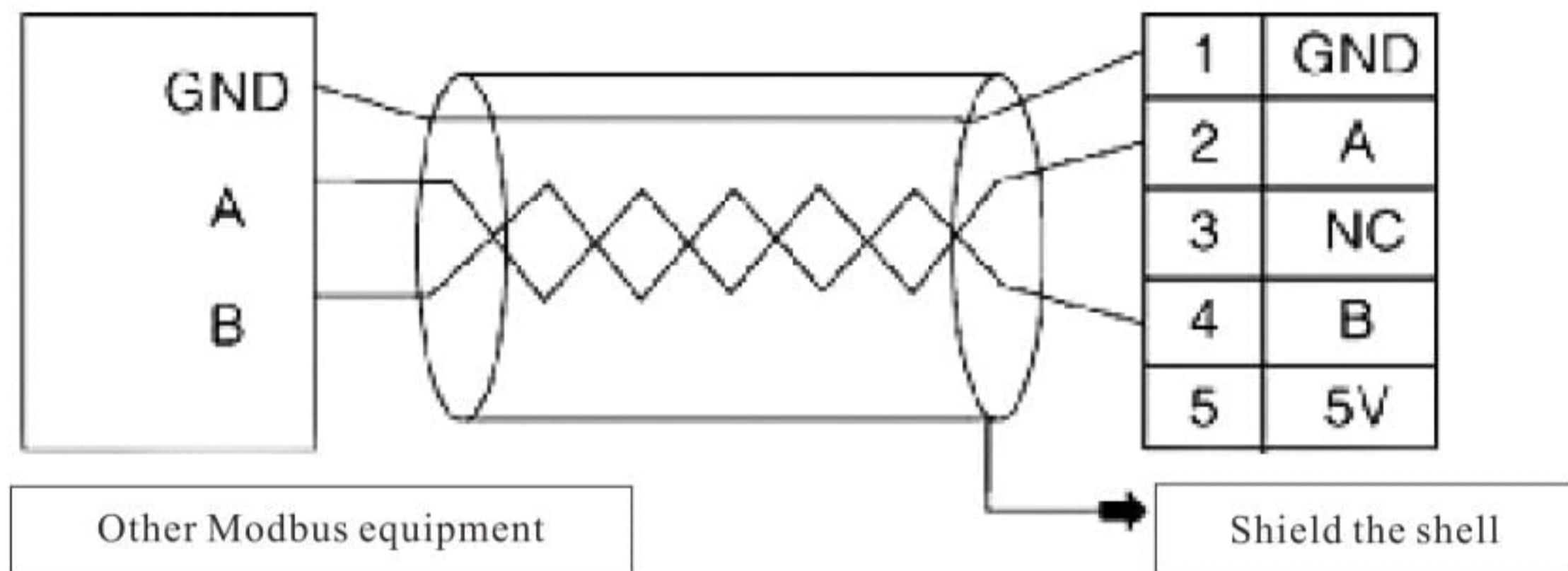

INOMAX

Build your trust of technology from China

SHENZHEN INOMAX TECHNOLOGY CO.LTD

Address: Ideal Science and Technology Park,
Guanlan Avenue, Longhua District, Shenzhen,
Guangdong, China

Tel: 0086-75521002258

Fax: 0086-75521002258

E-mail: info@inomaxtechnology.com

Websit: www.inomaxtechnology.com